



design & experience



design & experience



L'attenzione meticolosa alla qualità, la scelta accurata dei materiali, il gusto per la sperimentazione delle linee, le collaborazioni con designer di fama internazionale, uno sguardo sempre rivolto alla praticità dei prodotti e alla loro versatilità: l'esperienza si acquisisce col tempo, la professionalità si apprende con la passione, il successo si costruisce giorno dopo giorno.

**Vezzosi** questo lo sa e grazie al suo percorso può dimostrarlo.

Linee essenziali, dettagli ricercati, un design che cattura la semplicità della bellezza, una perfetta fusione tra l'esperienza nella tecnica e le esigenze contemporanee. Il prestigio della tradizione creativa italiana al servizio di **Vezzosi** per riscoprire l'essenzialità della bellezza, definire uno stile, identificarsi con un forte segno di riconoscimento. Per lasciare un' impronta che colpisce ed emoziona.

I materiali trendy e resistenti, selezionati e inalterabili rispondono alla necessità di dare il massimo della pregevolezza e al contempo valorizzare le strutture dal design contemporaneo scelte da **Vezzosi** per creare un nuovo concetto di salone funzionale e all'avanguardia.

**Vezzosi** mira a valorizzare la propria produzione **Made in Italy** per aiutare il consumatore a comprendere l'importanza del binomio "qualità e creatività".

qualità e creatività  
made in italy

## quality and creativity made in italy

*Attention to the quality, accurate choice of materials, taste for the experiment, collaboration with important designers, versatility of the articles: **Vezzosi** is experience, professionalism and success. Essential lines, refined details, this design captures the simplicity of the beauty as a perfect fusion between experience and contemporaneity.*

*The Italian tradition becomes emotion with **Vezzosi**.*

*Vezzosi uses trendy and resistant materials to emphasize the contemporary design and to create a new functional and modern salon.*

***Vezzosi** aims to emphasize its own production totally **Made in Italy** in order to help the customer understand the importance of the binomial: "quality and creativity".*

## qualità et créativité made in italy

*L'attention à la qualité, le choix soigné des matériaux, le goût pour la expérimentation, la collaboration avec designers connus dans le monde entier: cette expérience et ce caractère professionnel font partie du succès que **Vezzosi** construit jour par jour.*

*Lignes essentielles, détails recherchés, un design qui capture la simplicité de la beauté, une fusion parfaite entre les exigences techniques et les tendances modernes. Le prestige du design italien au service de*

***Vezzosi** pour laisser une empreinte qui touche et émotionne.*

*Les matériaux utilisés répondent à la nécessité de garantir la fiabilité et au même temps valoriser le nouveau concept de salon fonctionnel et à l'avant-garde.*

***Vezzosi** vise à valoriser sa propre production **Made in Italy** pour aider le client à comprendre l'importance du binôme "qualité et créativité".*





INDICE  
index  
index

01.  
pag. 08  
LAVAGGI  
washings  
lavages

CURVE art. 9805	11	DYLAN MASSAGE art. 3305	41
CURVE RELAX art. 9806	12	EDDIE art. 8060/16	43
CURVE MASSAGE art. 9807	12	EDDIE RELAX art. 8065/16	44
COOPER art. 3280	13	EDDIE MASSAGE art. 8069/16	44
COOPER RELAX art. 3285	15	EDDIE SOFÁ art. 8066	45
COOPER MASSAGE art. 3290	15	EDDIE SOFÁ RELAX art. 8067	45
URBAN RELAX art. 3855	17	EDDIE SOFÁ MASSAGE art. 8068	45
URBAN MASSAGE art. 3856	17	ROYAL WASH art. 8070	46
S-RELAX art. 9601	19	ROYAL WASH RELAX art. 8075	47
S-MASSAGE art. 9620	19	ROYAL WASH MASSAGE art. 8077	47
S-MAXI art. 9640	20	JO-WASH art. 8080	48
S-COLOR art. 9635	21	JO-WASH RELAX art. 8085	49
PUSH-UP RELAX art. 3350	22	JO-WASH MASSAGE art. 8087	49
PUSH-UP MASSAGE art. 3360	22	XILEMA WASH art. 3170	50
GALAXY WASH art. 3845	23	XILEMA RELAX art. 3180	50
GALAXY RELAX art. 3850	23	XILEMA AIRWASH art. 3175	50
HOP art. 3335	24	KUBIK FLAT art. 3197	52
HOP RELAX art. 3340	25	KUBIK RELAX FLAT art. 3199	53
HOP MASSAGE art. 3345	25		
POD art. 9001	27		
POD RELAX art. 9004	28		
POD AIR MASSAGE art. 9003	28		
NAPOLEONE art. 3130	29		
NAPOLEONE RELAX art. 3136	29		
NAPOLEONE III art. 3135	31		
NAPOLEONE III RELAX art. 3137	31		
NEXT art. 3800	32		
NEXT MASSAGE art. 3803	32		
NEXT RELAX art. 3802	33		
JAGO art. 3020	34		
JAGO RELAX art. 3025	35		
JAGO MASSAGE art. 3030	35		
NIRVANA art. 3250	36		
NIRVANA RELAX art. 3260	37		
NIRVANA MASSAGE art. 3270	37		
DYLAN art. 3295	40		
DYLAN RELAX art. 3300	41		

02.  
pag. 54

POLTRONE LAVORO  
rotaring chairs  
fauteuils tournants

CURVE art. 9856/9855	56
CURVE art. 9851/9850	57
FUNKY art. 9315	59
S-CHAIR art. 9310	60
POD art. 9010/ 9015	61
LUPE art. 1300	63
DORA art. 1310	64
CARNABY art. 1396	65
EPOQUE art. 9311	66
TRAFALGAR art. 8175	67
PICCADILLY art. 1398	68
GAGA art. 1338	69
OXFORD art. 1397	70
DEVIL art. 1327	71
UMA art. 1350	73
SAHARA art. 1340	74
ROYAL art. 8125	75
MEG art. 8145	76
AVATAR art. 9308	77
KELLY art. 8167	77
VIKY art. 8146	78
SCARLETT art. 8148	78
APPLE art. 8136	79
XILEMA CHAIR art. 1399	79
ALLISON art. 1395	80
FRIDA art. 1320	81
EVA art. 1321	82
GINGER art. 1325	83
GINGERMAN art. 1326	84
ADAM art. 1322	85
DANDY art. 8169	87
NEWTON PLUS art. 9314	88
CASANOVA art. 9313	89

03.  
pag. 90

POLTRONE ATTESA  
waiting chairs  
fauteuils attente

CURVE art. 9872	93
LOLITA art. 2245	94
LITTLE SHINE art. 2790	95
DUBAI art. 2985	96
FUSION art. 5800	97
NAPOLEONE WAITING art. 2160	98
WHITE art. 2975/2970	99
XILEMA WAITING art. 2090/2091	100
XILEMA SOFÁ art. 2095/2096	101
POD WAITING art. 9020/9025	103
GOSPEL art. 2240/2243	104
GOSPEL SOFÁ art. 2241/2244	105
GINEVRA art. 2280/2281	106
GINEVRA SOFÁ art. 2282/2283	107
STAR art. 2130	108
STAR3 art. 2135	108
IL RETTANGOLO art. 2900	109
IL BACELLO art. 2950	109
QUADROTTO art. 2800	109
ROYAL WAITING art. 8320	111
ROYAL SOFÁ art. 8325	111
SWEET art. 8300	112
BEVERLY art. 8335	112
FEEEL art. 8310	113
SINGLE art. 8305	113

# 04.

pag. 114

POSTI LAVORO  
styling units  
coiffeuses

CURVE art. 9828	116	XILEMA DOUBLE art. 4155	160
CURVE art. 9829	117	XILEMA WALL art. 4150	161
CURVE art. 9836	119	XILEMA ISLAND art. 4160	162
CURVE art. 9826/9825	120	KOMODO art. 4165	163
CURVE art. 9821/ 9822	121	MOVIE art. 8241/16	165
NEW AGE WALL art. 9338	122	SUPERNOVA art. 8269	167
NEW AGE ISLAND art. 9339	123	LIBERTY art. 8268	168
FELIPE art. 4039	124	ROYAL WALL art. 8266	169
EDEN art. 8275	126	ROYAL DOUBLE art. 8271	170
EDEN + art. 8275P	127	ROYAL ISLAND art. 8270	171
CLEOPATRA WALL art. 4100	130	WATCH art. 9328	173
CLEOPATRA art. 4105	131	WATCH+ art. 9228	174
GIOTTO art. 8246	132	IKON art. 8245	175
GIOTTO+ art. 8247	133	STRIPE LIGHT art. 8218/16	177
S-WALL art. 5150	135	STRIPE art. 8217/16	177
POLARIS art. 5180	136	ONE LIGH art. 8234/16 T	178
POLARIS+ art. 5181	137	DOS LIGHT art. 8236/16	179
POLARIS WALL art. 5182	138	OPERA art. 9342	180
DESIGN art. 4098	139	OPERA WALL art. 9343	181
NATURAL DOUBLE art. 9324	140	RING art. 9335	183
NATURAL+ art. 9326	141	NETWORK art. 9336	184
NATURAL LIGHT art. 9321	142	WAVE art. 9337	185
QUEEN LIGHT art. 4009/B-4009	143	MESH LIGHT art. 5170/B	186
FLAVIA art. 8242/16	144	MESH art. 5170	186
PASSION GLASS LIGHT art. 4007	145	JUMPER art. 5165	187
PASSION GLASS art. 4008	145	KRYPTO LIGHT art. 5160	189
WHITESTONE art. 4037	146	KRYPTO art. 5155	189
BLACKSTONE art. 4035	147	CLASH 1 art. 8233	190
SOPHIA ONE art. 4021	148	CLASH art. 8230	191
SOPHIA art. 4023	149	CURVE BARBIERE art. 9845	192
SOPHIA WALL art. 4022	150	CURVE BARBIERE art. 9840	193
MARILYN ISLAND art. 4030	151	JAZZ art. 4191L/4191R	194
MAKE UP art. 4038	153	GOYA art. 8272	195
EPOQUE WALL art. 9327	156	GALILEO art. 5190	196
EPOQUE WALL+ art. 9327/P	157	FIGARO art. 5050	197
EPOQUE 1 art. 9330	158	RETRÒ 2.0 art. 5052	200
BAROQUE art. 9325	159	RETRÒ art. 5051	201

# 05.

pag. 202

TAVOLI CASSA  
cash register table  
tables caisse

NEW AGE DESK art. 6810	205
CURVE CASSA art. 9815	206
LOVE art. 6755	207
A. LIGHT art. 9950	209
POD RECEPTION art. 9550	210
POD RECEPTION art. 9500	211
COLOUR DESK art. 6300	212
MOON RECEPTION art. 6000	213
LUZ art. 6758	214
XILEMA DESK art. 6800	215
CORNER DESK art. 6756	216
PEPITA art. 6757	217
NATURAL DESK art. 6190	218
MARILYN DESK art. 6030	219
AUDREY art. 8417	221
AMELIE art. 8426	222
DORIAN art. 8425	223
ROYAL DESK art. 8424	226
SMILE art. 8416	226
LUMINOL art. 8414	227
J-LO DESK art. 8415	227
SPICE art. 8410	228
WELCOME art. 8428	229

# 06.

pag. 230

MOBILI EXPO  
expo furnishing  
meubles expo

CURVE EXPO art. 9895	232
JUMPER art. 565	233
NATURAL EXPO art. 506	236
XILEMA art. 510	237
SKAI EXPO MAXI art. 504	238
SKAI EXPO art. 505	238
EXPO NEW art. 8601/16	239
DADA art. 8604	240
REALITY EXPO art. 8603	241

# 07.

pag. 242

MOBILI SERVIZIO  
salon furnishing  
meubles de rangement

CURVE MOBILE art. 9885	245
COLOUR SERVICE art. 6305	246
WOOD art. 9360/B	247
BEAUTY art. 9355	249
LUXURY art. 9350	251
MOBILI art. 707	252
MOBILI art. 706	253
MOBILI art. 705	254
MOBILI art. 702	255
MOBILI art. 8730/16	256
MOBILI art. 8731/16	257
MOBILI art. 8726	258
MOBILI art. 8725/16-8720/16 - 8700/16	259

# 08.

pag. 260

COMPLEMENTI  
compléments

XILEMA CLOSET art. 7195	262
GRAFFIO art. 7190	263
SOUL art. 4225	264
TOTEM art. 4220	264
YORK art. 4201	264
BRAD art. 8251/16	265
STYLE art. 8250	265
SWING art. 4231	266
ROCK art. 4230	266
METEOR+ art. 4190P	267
METEOR BASIC art. 5075	267
OPERA SERVICE art. 4232	269
COOL art. 4215	269
YOUNG art. 7271	270
OZZY art. 7272	270
HOLLY art. 7277	271
WOW art. 7270	271
FLUYDO art. 8428	271
CURVE PORTAPHON art. 9890	272
PORTAPHON art. 7256	272
A. PORTAPHON art. 7255	272
VORTICE art. 7250	272
VALENTINO art. 5070	273
VOGUE art. 7279	273
IRON art. 7275	273
FRIEND art. 7290	274
HOLLYWOOD art. 7291	274
TENDER DOUBLE art. 7292	275
TENDER art. 7293	275
ENERGY art. 7145	276
BOLERO art. 7143	276
FELIX art. 8253	277
KID art. 8252	277

# 09.

pag. 278

ESTETICA  
beauty items  
esthétique

PITAGORA art. 10025/N	280
POPPER art. 10015/N	281
TIFFANY art. 10055/N	283
HARRY art. 10035/N	284
DANY art. 10091/N	284
IGGY art. 10090/N	285
KIMI art. 10060/B	285
MARILYN NAILS art. 10105/N	286
EXPO NAILS art. 10106/N	286
GRACE+ art. 10065/N16	287
GRACE DOUBLE art. 10064/N	287
LOU art. 10080/N	288
JOEY art. 10075/N	288
ALICE art. 10085/N	289
ALICE CON PIEDE art. 10086/N	289
NELLY art. 10095/N	289

# 10.

pag. 290

POGGIA PIEDI - PIEDI  
foot-rest and feet  
repose-pieds - pieds

POGGIAPIEDI art. 7340	292
POGGIAPIEDI art. 7335	292
POGGIAPIEDI art. 7310	292
POGGIAPIEDI art. 7315	292
POGGIAPIEDI art. 9970	292
POGGIAPIEDI art. 7300	293
POGGIAPIEDI art. 7330	293
POGGIAPIEDI art. 7325	293
POGGIAPIEDI art. 5600	293
POGGIAPIEDI art. 9390	293
PIEDI art. P20/21	294
PIEDI art. P30/31	294
PIEDI art. P80/81	294
PIEDI art. P05	294
PIEDI art. P15	294
PIEDI art. P70	295
PIEDI art. P51	295
PIEDI art. P40/41	295
PIEDI art. P98/99	295
PIEDI art. P90/95	295

# 11.

pag. 296

CASCHI  
hairdryer  
sechoir

GOKU art. 1150/1160/1170	298
VICTOR art. 1610/1620	299
GINKO art. 1100/1120/1100	300
DARWIN art. 1000/1010/1120	301
RADIUS art. 1200/1210/1220	302
LUCÉ art. 1800/1810/1820	303

# 12.

pag. 304

SCHEMI IDRAULICI  
hydraulic plans  
schémas hydrauliques

CURVE art. 9805/9806/9807	306
URBAN art. 3855/ 3856	307
PUSH UP art. 3350/ 3360	307
S RELAX art. 9601	308
S MASSAGE art. 9620	308
S COLOR art. 9635	308
S MAXI art. 9640	308
GALAXY art. 3845/3850	308
HOP art. 3335/ 3340/ 3345	309
XILEMA art. 3170/ 3180/ 3175	309
POD art. 9001/9003/9004	310
NAPOLEONE art. 3130/ 3135	311
NAPOLEONE III art. 3136/ 3137	311
NEXT art. 3800/ 3802/ 3803	312
NIRVANA art. 3250/ 3260/ 3270	313
JAGO art. 3020/ 3025/ 3030	314
COOPER art. 3080/ 3085/ 3090	315
DYLAN art. 3295/ 3300/ 3305	316
KUBIK art. 3197/ 3199	317
EDDIE art. 8060/ 8065/ 8069	318
EDDIE SOFÁ art. 8066/ 8067/ 8068	319
ROYAL WASH art. 8070/ 8075/ 8077	320
JO WASH art. 8080/ 8085/ 8087	321

# 13.

pag. 330

COLORI E MATERIALI  
colours and materials  
coloris et matériaux

TAPPEZZERIA UPHOLSTERY TAPISSERIE	
NORMAL SKAI	324
SPECIAL SKAI	325
TOP SKAI	326
LAMINATI PRE-LAMINATED LAMINE	327



01.

LAVAGGI  
washings  
lavages





# Denis Santachiara



CURVE: a modern collection with an innovative design and sinuous lines, the perfect union between form and function.  
 CURVE by Santachiara writes a new page in the Design world.  
 The creative impulse has been cultivated with curiosity, freedom and intensity. This is how Curve is born, the new collection that permits us to keep telling our story after POD and APP collections.  
 Denis Santachiara is not your run-of-the mill designer and is something of an outsider on the international circuit, but he is renowned for his works of art and design, which are exhibited in museums and events all over the world. Featured at the Venice Biennial back in the early Eighties, his works can now be seen in the permanent collections at the Moma in New York, at the National Museum of Modern Art in Tokyo and the Musée des Arts Décoratifs at the Louvre and at the Milan Triennial.  
 If we had to define Denis Santachiara using a synonymus of Designer, we could use with no doubts the word "Inventor".

## CURVE

by Santachiara

CURVE: una linea moderna, innovativa e dal design ricercato, dalle linee sinuose, il perfetto connubio tra forma e funzione.  
 Curve by Santachiara riscrive una pagina nel mondo del design.  
 L'impulso creativo è stato coltivato con curiosità, libertà e intensità e così è nata CURVE, nuova linea che ci dà la possibilità di continuare a raccontare la nostra storia dopo POD e APP.  
 E' attraverso la scelta dei particolari che si esprime la personalità di un arredo, il salone diventa un palcoscenico dove si assiste ad un cambiamento.  
 Denis Santachiara, designer anomalo e outsider nel panorama internazionale, famoso per le sue opere tra arte e design, esposte in musei e manifestazioni in tutto il mondo. Ospite alla Biennale di Venezia già agli inizi degli anni Ottanta, è presente con collezioni permanenti al Moma di New York, al National Museum of Modern Arts di Tokyo, al Musée des Arts Décoratifs del Louvre e alla Triennale di Milano.  
 Quando si parla di Denis Santachiara si parte dal concetto di "sorprensione", un termine che lui stesso ha coniato per spiegare il suo design, i suoi interni, gli arredi e gli allestimenti davvero unici nel panorama del progetto: sono oggetti e progetti che innovano e che fanno della trasformabilità non una artificiale e artificiosa caratteristica, quanto l'unica caratteristica possibile.  
 Se dovessimo definire Santachiara cercando un sinonimo di designer, potremmo senza paura scomodare un termine che sembra coniato per lui: inventore.

CURVE: une collection moderne avec un design novateur et des lignes sinueuses, la combinaison parfaite entre la forme et la fonction.  
 L'impulsion creative a été cultivée avec curiosité, liberté et intensité; dans cette manière est née Curve, la nouvelle collection qui nous permet de continuer à raconter notre histoire après Pod et App collections.  
 Denis Santachiara designer hors du commun et outsider dans le panorama international de l'innovation, Denis Santachiara est célèbre pour ses oeuvres à mi-chemin entre art et design, exposées dans les musées du monde entier et à l'occasion de nombreuses manifestations.  
 Invité à la Biennale de Venise dès le début des années 80, Santachiara est présent à travers des collections permanentes au Moma de New York, au National Museum of Modern Art de Tokyo, au Musée des Arts Décoratifs du Louvre, ainsi qu'à la Triennale de Milan.  
 Si on devait définir Denis Santachiara avec un synonyme de Designer on pourrait utiliser sans aucun doute le mot "inventeur".

**VEZZOSI**

# CURVE lavaggio

Art. 9805

**CURVE**  
by Santachiara

Piattaforma e colonnetta in materiale poliuretano, livello basculante supporto poltrona in vetroresina, tappezzeria in skai.

Base and column in polyurethane material, chair stand in fiberglass, tilting basin, upholstery in skai.

Plate forme et colonne en matériel poliuréthane, cuvette basculante, structure du fauteuil en fibre de verre, tapisserie en skai.



Disponibile anche con struttura grigia.  
 Available with grey structure.  
 Disponible avec structure gris.



## UTILITY

Art. 3815

Utility in acciaio inox con vaschetta in ceramica bianca, non incluso

Utility in steel with pottery basin white, not included.

Utility en acier inox, basin en céramique blanc, pas inclus.

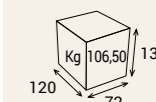
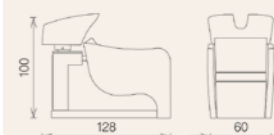
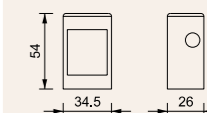

Art. 9806

# CURVE relax

**CURVE**  
by Santochiara

Poggiagambe regolabile elettricamente fino alla posizione relax.

*Upholstery in skai, adjusting leg rest by electronic.*

*Repose pieds réglable jusqu'à la position relax.*



**AIR MASSAGE CURVE**  
**massage**  
Art. 9807

Massaggio totale linfodrenante a flusso d'aria a variazione continua su tutto il corpo.

*Full lymph-draining and invigorating massage by air flux over the whole body.*

*Massage total lymph-drainant par flux d'air a variation continue sur tout le corps.*

Accesso facile.  
Easy access.  
Accès facile.



Disponibile anche con struttura grigia.  
Available with grey structure.  
Disponible avec structure gris.

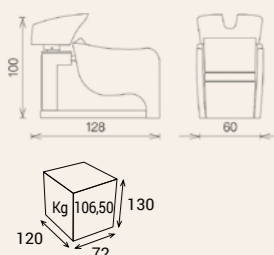

# COOPER

Art. 3280

Piattaforma e colonnetta in materiale poliuretanico, lavello basculante, tappezzeria in skai.

*Base and column in polyurethane material, tilting basin, upholstery in skai.*

*Plate forme et colonne en materiel poliurethane, cuvette basculante, tapisserie en skai.*



## UTILITY

Art. 3815

Utility in acciaio inox con vaschetta in ceramica bianca, non incluso

*Utility in steel with pottery basin white, not included.*

*Utility en acier inox, basin en ceramique blanc, pas inclus.*

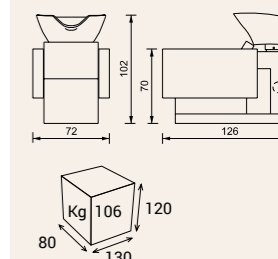
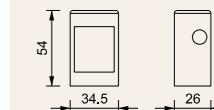





# COOPER relax

Art. 3285

Poggiagambe regolabile elettricamente fino alla posizione relax.

*Upholstery in skai, adjusting leg rest by electronic.*

*Repose pieds réglable jusqu'à la position relax.*



## Optional ONE TOUCH

Alzagambe ad impulso automatico.

*Automatic impulse leg lifters.*

*Leviers de jambes à impulsion automatique.*



## COOPER massage AIR MASSAGE

Art. 3290

Massaggio totale linfodrenante a flusso d'aria a variazione continua su tutto il corpo.

*Full lymph-draining and invigorating massage by air flux over the whole body.*

*Massage total lymph-drainant par flux d'air à variation continue sur tout le corps.*

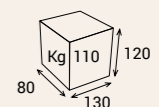
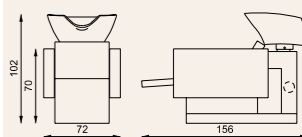



# URBAN relax

Art. 3855

Lavello a doppia regolazione basculante e scorrevole, servizio total relax regolabile elettricamente, sottolavello in materiale poliuretano bianco con portabottiglie incorporato, tappezzeria in skai.

*Wash unit with electronic leg rest and with double movement of the basin (tilting and sliding), frame in polyurethane material with shampoo holders, upholstery in skai.*

*Cuvette avec double réglage basculante et coulissante. Service de total relax réglable par l'électronique. Top postérieur en matériel poliurethane blanc avec porte shampoings. Tapisserie en skai.*



## Optional ONE TOUCH

Alzagambe ad impulso automatico.

*Automatic impulse leg lifters.*

*Leviers de jambes à impulsion automatique.*



## URBAN massage AIR MASSAGE

Art. 3856

Massaggio totale linfodrenante a flusso d'aria a variazione continua su tutto il corpo.

*Full lymph-draining and invigorating massage by air flux over the whole body.*

*Massage total lymph-drainant par flux d'air à variation continue sur tout le corps.*

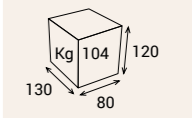
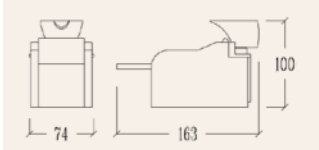





# S-RELAX

Art. 9601



Struttura in vetroresina, doppio movimento del lavabo, basculante e scorrevole, poltrona regolabile elettricamente, fino alla posizione relax.

*Structure in fiberglass, double movement of the basin, tilting and sliding, adjusting seat by electronic up to the relax position.*

*Structure en fibre de verre, double mouvement de la cuvette, basculante et coulissante, fauteuil réglable jusqu'à la position de relax.*

Optional: diffusori aromi sensoriali.  
Optional: diffusor of sensorial fragrances.  
Optional: distributeur de aromes sensoriels.



# S-MASSAGE

Art. 9620 AIR MASSAGE

Massaggio totale linfodrenante a flusso d'aria a variazione continua su tutto il corpo.

*Full lymph-draining and invigorating massage by air flux over the whole body.*

*Massage total lymph-drainant par flux d'air a variation continue sur tout le corps.*

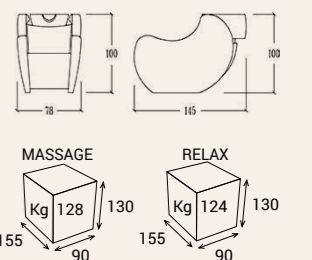

# S-MAXI

Massaggio totale linfodrenante a flusso d'aria a variazione continua su tutto il corpo, display 15" per riproduzione immagini e filmati, dock station per ipod o iphon (non inclusi), porta usb (chiavetta inclusa), casse audio, vano porta shampoo, tappezzeria.

*Full lymph-draining and invigorating massage by air flux over the whole body, audio speakers, shampoo holder, display 15" to launch images and videos, dock station for ipod or iphon, upholstery.*

*Fauteuil réglable jusqu'à la position de relax, massage total lymph drainant par flux d'air à variation continue sur tout le corps, display 15" pour reproduction images et video, tapisserie.*

Optional: diffusori aromi sensoriali.  
Optional: diffusor of sensorial fragrances.  
Optional: distributeur de aromes sensoriels.

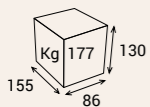
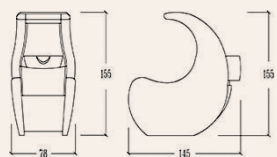

# S-COLOR

Massaggio totale linfodrenante a flusso d'aria a variazione continua su tutto il corpo. Jack audio per lettore mp3 o smartphone, casse audio, vano porta shampoo, trasmissione di colori emozionali.

*Full lymph-draining and invigorating massage by air flux over the whole body. Audio jack for mp3 players and smartphones, speakers, shampoo holders. transmission of relaxing colours integrated.*

*Massage total lymph drainant par flux d'air à variation continue sur tout le corps.*

*Jack audio pour les lecteurs mp3 et smartphones, porte shampoo, transmission de couleurs emotionnels intégré.*

Optional: diffusori aromi sensoriali.  
Optional: diffusor of sensorial fragrances.  
Optional: distributeur de aromes sensoriels.

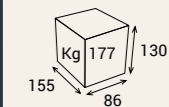
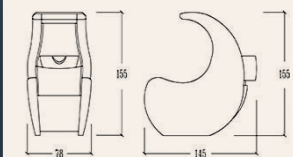
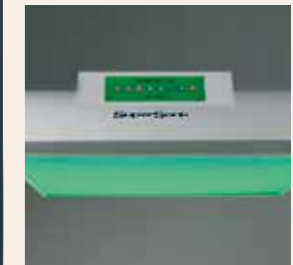



Art. 3350

# PUSH-UP relax

Lavaggio CERTIFICATO APAVE A NORME EUROPEE, lavello basculante, struttura completamente regolabile elettricamente in altezza. Poggiagambe regolabile elettricamente.

Washunit CERTIFIED BY APAVE, COMPLYING TO THE EUROPEAN REGULATIONS EN 14738. Electronic adjustment of the height of the complete system, electronic leg rest.

Bac certifié par APAVE EN RESPECT DE LA NORME EUROPEENNE EN 14738. Réglage électrique en hauteur du dispositif entier. Repose-pieds réglable par l'électronique.

## Optional ONE TOUCH

Alzagambe ad impulso automatico.

Automatic impulse leg lifters.

Leviers de jambes à impulsion automatique.



## PUSH-UP massage

Art. 3360

Massaggio totale linfodrenante a flusso d'aria a variazione continua nella seduta e nello schienale.

Full lymph-draining and invigorating massage by air flux in the back and in the seat.

Massage total lympho-drainant par flux d'air à variation continue sur l'assise et sur le dossier.

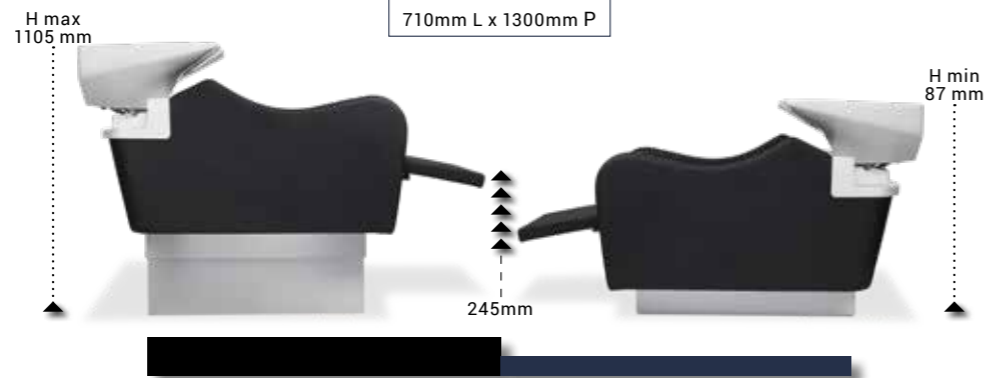
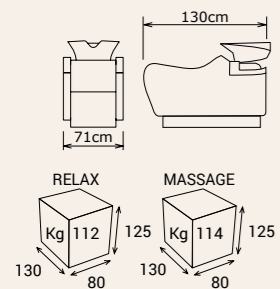

# GALAXY wash

Art. 3845

Lavaggio a divano, struttura laminato plastico, lavelli color bianco basculanti, lavello inox completo di gruppo idraulico tra le due vasche tappezzeria in skai.

Sofa washing unit, structure in plastic laminated, tilting basin, inox sink complete of hydraulic group between the two basins upholstery in skai.

Bac sofa, structure en stratifié, évier inox entre les 2 cuvettes, tapisserie en skai.

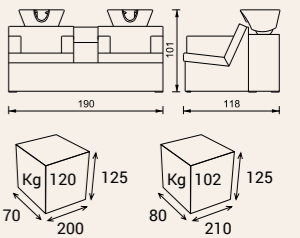

## GALAXY relax Art. 3850

Poggiagambe regolabile elettricamente per servizio relax, tappezzeria in skai.

Adjusting seat by electronic up to the relax position, upholstery in skai.

Repose-jambes relax électrique, tapisserie en skai.



## Optional ONE TOUCH

Alzagambe ad impulso automatico.

Automatic impulse leg lifters.

Leviers de jambes à impulsion automatique.



GALAXY relax Art. 3850

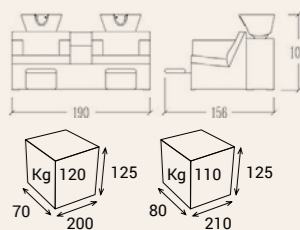

Art. 3335

# HOP

Lavello basculante, sotto lavello in materiale poliuretano con portashampoo incorporato, tappezzeria in skai.

*Wash unit with tilting basin, frame in polyurethane material with shampoo holders, upholstery in skai.*

*Cuvette basculante, top posterieur en materiel poliurethane blanc avec porte shampoings incorpore'. Tapisserie en skai.*

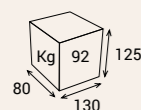
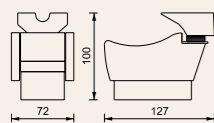

# HOP relax

Art. 3340

Poggiagambe regolabile elettricamente per servizio relax.

*Wash unit with electronic leg rest.*

*Repose pieds relax réglable par l'électronique.*



## Optional ONE TOUCH

Alzagambe ad impulso automatico.

*Automatic impulse leg lifters.*

*Leviers de jambes à impulsion automatique.*



## HOP massage

Art. 3345 

Massaggio totale linfodrenante a flusso d'aria a variazione continua nella seduta e nello schienale.

*Full lymph-draining and invigorating massage by air flux in the back and in the seat.*

*Massage total lymph-drainant par flux d'air à variation continue sur l'assise et sur le dossier.*

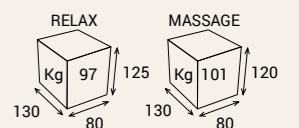
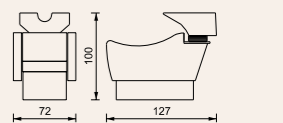



# POD lavaggio

Art. 9001



Struttura in materiale poliuretano color bianco, lavello basculante, base acciaio lucido, tappezzeria in skai.

*Frame in polyurethane material colour white, tilting basin, shine in steel base, upholstery in skai.*

*Structure en materiel poliurethane couleur blanc, cuvette basculante, base en acier brillant, tapisserie en skai.*

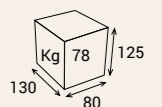
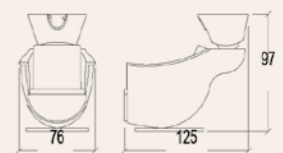



Art. 9004

# POD relax



Poggiagambe regolabile elettricamente.

*Adjusting leg-rest by electronics.*

*Appui-jambes réglable par l'électronique.*



## Optional ONE TOUCH

Alzagambe ad impulso automatico.

*Automatic impulse leg lifters.*

*Leviers de jambes à impulsion automatique.*



## POD air massage Art. 9003

Massaggio totale linfodrenante a flusso d'aria a variazione continua nella seduta e nello schienale.

*Full lymph-draining and invigorating massage by air flux in the back and in the seat.*

*Massage total lymph-drainant par flux d'air à variation continue sur l'assise et sur le dossier.*

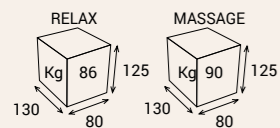
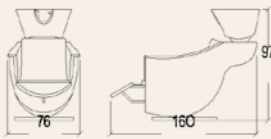

# NAPOLEONE

Art. 3130

Divano lavaggio, colonne in materiale poliuretano color bianco, livello basculante, utility in acciaio con vaschetta in ceramica bianca, tappezzeria in skai.

*Wash unit sofa, columns in polyurethane material colour white, tilting basin, utility in steel with pottery basin white, upholstery in skai.*

*Bac sofa, colonnes en matériel polyuréthane couleur blanc, cuvette basculante, utility en acier avec bassin en ceramique blanc, tapisserie en skai.*

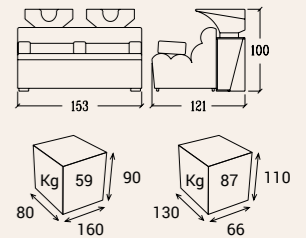

## NAPOLEONE relax Art. 3136

Poggiagambe regolabile elettricamente.

*Adjusting leg-rest by electronics.*

*Appui-jambes réglable par l'électronique.*



NAPOLEONE relax Art. 3136

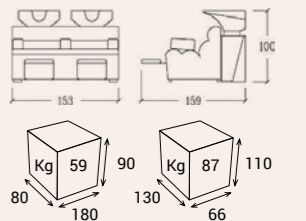



# NAPOLEONE III

Art. 3135

Divano lavaggio, colonne in materiale poliuretano color bianco, livello basculante, utility in acciaio con vaschetta in ceramica bianca, tappezzeria in skai.

*Wash unit sofa, columns in polyurethane material colour white, tilting basin, utility in steel with pottery basin white, upholstery in skai.*

*Bac sofa, colonnes en materiel polyurethane couleur blanc, cuvette basculante, utility en acier avec basin en ceramique blanc, tapisserie en skai.*

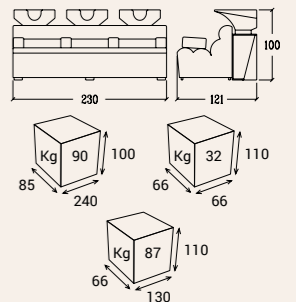

NAPOLEONE III relax Art. 3137



## UTILITY Art. 3810

Utility in acciaio inox con vaschetta in ceramica bianca incluso.

*Utility in steel with pottery basin white included.*

*Utility en acier inox, basin en ceramique blanc inclus.*

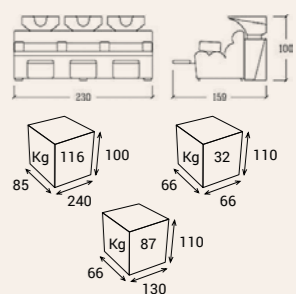

## NAPOLEONE III relax Art. 3137

Divano lavaggio con poggiatesta regolabile elettricamente servizio relax.

*Wash unit sofa, with electronic leg rest, tilting basin.*

*Bac sofa avec repose pieds relax réglable par l'electronique.*



Art. 3800

# NEXT

Lavello a doppia regolazione basculante e regolabile in altezza, sotto lavello in acciaio inox, colonna in materiale poliuretano, tappezzeria in skai.

Wash unit with double movement of the basin (tilting and adjusting in height), frame in polyurethane material and steel material under the basin, upholstery in skai.

Cuvette avec double réglage basculante et en hauteur, top postérieur en inox, colonne en matériel poliurethane. Tapisserie en skai.

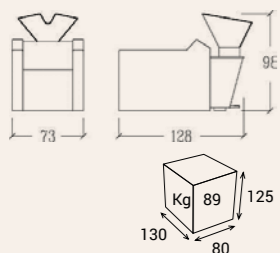

## NEXT massage Art. 3803

Massaggio totale linfodrenante a flusso d'aria a variazione continua nella seduta e nello schienale.

Full lymph-draining and invigorating massage by air flux in the back and in the seat.

Massage total lymph-drainant par flux d'air à variation continue sur l'assise et sur le dossier.

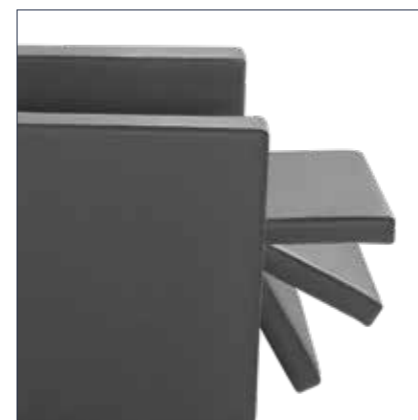
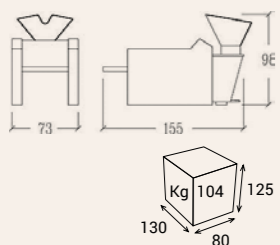
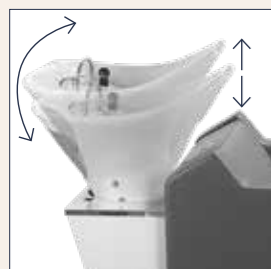

# NEXT relax

Art. 3802

Poggiagambe regolabile elettricamente per servizio relax.

Wash unit with electronic leg rest.

Repose pieds relax réglable par l'électronique.



## Optional ONE TOUCH

Alzagambe ad impulso automatico.

Automatic impulse leg lifters.

Leviers de jambes à impulsion automatique.



## UTILITY Art. 3810

Utility in acciaio inox con vaschetta in ceramica bianca, non incluso.

Utility in steel with pottery basin white, not included.

Utility en acier inox, basin en ceramique blanc, pas inclus.

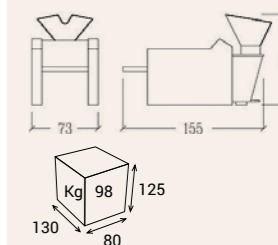



Art. 3020

# JAGO

Struttura imbottita e ricoperta in skai, lavello bascuante, porta shampo posteriore.

Frame guilteed and covered with skai, tilting basin, shampoo holder on the backside.

Structure rembournee'et recouverte en skai, cuvette blanche basculante, porte shampoings posterieur.



## UTILITY

Art. 3815

Utility in acciaio inox con vaschetta in ceramica bianca, non incluso

Utility in steel with pottery basin white, not included.

Utility en acier inox, basin en ceramique blanc, pas inclus.

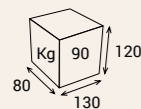
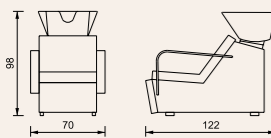
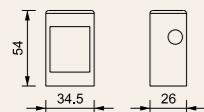

# JAGO relax

Art. 3025

Poggiagambe regolabile elettricamente per servizio relax.

Wash unit with electronic leg rest.

Repose pieds relax réglable par l'electronique.



## Optional ONE TOUCH

Alzagambe ad impulso automatico.

Automatic impulse leg lifters.

Leviers de jambes à impulsion automatique.



## JAGO massage Art. 3030

Massaggio totale linfodrenante a flusso d'aria a variazione continua nella seduta e nello schienale.

Full lymph-draining and invigorating massage by air flux in the back and in the seat.

Massage total lymph-drainant par flux d'air a variation continue sur l'assise et sur le dossier.

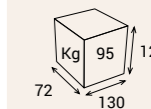
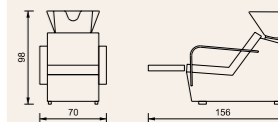

Art. 3250

# NIRVANA

Lavello basculante, sotto lavello in materiale poliuretano con portashampoo incorporato, tappezzeria in skai.

*Wash unit with tilting basin, frame in polyurethane material with shampoo holders, upholstery in skai.*

*Cuvette basculante, top posterieur en materiel poliurethane blanc avec porte shampoings incorpore'. Tapissierie en skai.*

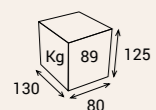
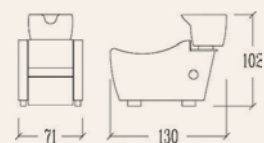

# NIRVANA relax

Art. 3260

Poggiagambe regolabile elettricamente, tappezzeria in skai.

*Adjusting leg-rest by electronics, upholstery in skai.*

*Appui-jambes réglable par l'électronique, tapisserie en skai.*



## Optional ONE TOUCH

Alzagambe ad impulso automatico.

*Automatic impulse leg lifters.*

*Leviers de jambes à impulsion automatique.*



## NIRVANA massage

Art. 3270 AIR MASSAGE

Massaggio totale linfodrenante a flusso d'aria a variazione continua nella seduta e nello schienale.

*Full lymph-draining and invigorating massage by air flux in the back and in the seat.*

*Massage total lympho-drainant par flux d'air à variation continue sur l'assise et sur le dossier.*

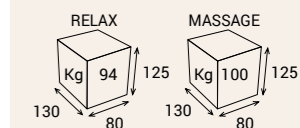
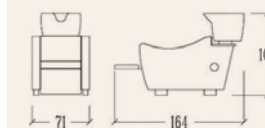





Art. 3295

# DYLAN

Struttura imbottita e ricoperta in skai, lavello basculante, sotto lavello e scocca posteriore in materiale poliuretano.

*Frame quilted and covered with skai, tilting white basin, under top and backside in polyurethane material.*

*Structure rembournée et recouverte en skai, couvette blanche et basculante, posterieur et top en materiel poliurethane.*



## UTILITY

Art. 3815

Utility in acciaio inox con vaschetta in ceramica bianca, non incluso

*Utility in steel with pottery basin white, not included.*

*Utility en acier inox, basin en ceramique blanc, pas inclus.*

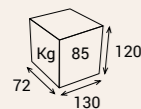
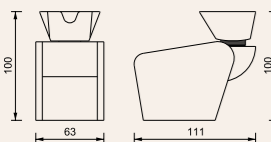
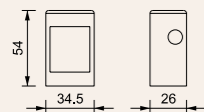

# DYLAN relax

Art. 3300

Poggiagambe regolabile elettricamente, tappezzeria in skai.

*Adjusting leg-rest by electronics, upholstery in skai.*

*Appui-jambes réglable par l'électronique, tapisserie en skai.*



## Optional ONE TOUCH

Alzagambe ad impulso automatico.

*Automatic impulse leg lifters.*

*Leviers de jambes à impulsion automatique.*



## DYLAN massage

Art. 3305 AIR MASSAGE

Massaggio totale linfodrenante a flusso d'aria a variazione continua su tutto il corpo.

*Full lymph-draining and invigorating massage by air flux over the whole body.*

*Massage total lymph-drainant par flux d'air a variation continue sur tout le corps*

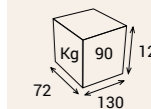
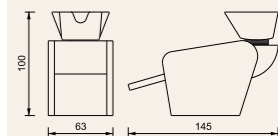





# EDDIE

Art. 8060/16

VEZZOSIEMPORIO

Struttura imbottita e ricoperta in skai, lavello bianco basculante, porta shampoo posteriore, tappezzeria in skai.

*Frame gilded and covered with skai, tilting white basin, shampoo holder on the backside, upholstery in skai.*

*Structure rembournée et recouverte en skai, cuvette blanche basculante, porte shampoings posterieur, tapisserie en skai.*



## PANNELLO

Art. 3575

Pannello copritubi in materiale poliuretano color nero, non incluso.

*Panel for covering the pipes in polyurethane colour black, not included.*

*Panneau pour couvrir les tuyaux en materiel poliurethane couleur noir, non inclus.*

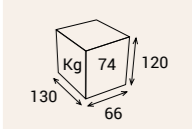
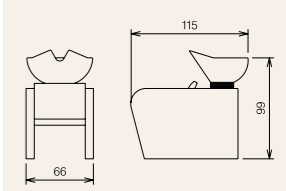

Art. 8065/16

# EDDIE relax

VEZZOSIEMPORIO

Poggiagambe regolabile elettricamente, tappezzeria in skai.

*Adjusting leg-rest by electronics, upholstery in skai.*

*Appui-jambes réglable par l'électronique, tapisserie en skai.*



## Optional ONE TOUCH

Alzagambe ad impulso automatico.

*Automatic impulse leg lifters.*

*Leviers de jambes à impulsion automatique.*



## EDDIE massage

Art. 8069/16

Massaggio totale linfodrenante a flusso d'aria a variazione continua nella seduta e nello schienale.

*Full lymph-draining and invigorating massage by air flux in the back and in the seat.*

*Massage total lympho-drainant par flux d'air à variation continue sur l'assise et sur le dossier.*

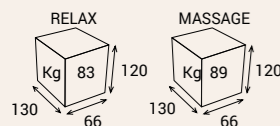
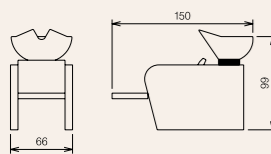

## PANNELLO Art. 3575

Pannello copritubi in materiale poliuretano color nero, non incluso.

*Panel for covering the pipes in polyurethane colour black, not included.*

*Panneau pour couvrir les tuyaux en matériel polyuréthane couleur noir, non inclus.*

# EDDIE SOFÁ

Art. 8066

VEZZOSIEMPORIO

Divano lavaggio, struttura imbottita e ricoperta in skai, colore tappezzeria a scelta, lavello basculante a scelta, lavello basculante, porta shampo posteriore.

*Wash unit sofa, frame quilted and covered with skai, tilting white basin, shampoo holder on the backside, upholstery in skai.*

*Bac sofa, structure rembournée et recouverte en skai, cuvette blanche basculante, porte shampoings postérieur, tapisserie en skai.*

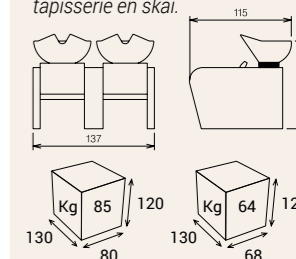

## EDDIE SOFÁ relax

Art. 8067

Poggiagambe regolabile elettricamente, tappezzeria in skai.

*Adjusting leg-rest by electronics, upholstery in skai.*

*Appui-jambes réglable par l'électronique, tapisserie en skai.*



## Optional ONE TOUCH

Alzagambe ad impulso automatico.

*Automatic impulse leg lifters.*

*Leviers de jambes à impulsion automatique.*



## EDDIE SOFÁ massage

Art. 8068

Massaggio totale linfodrenante a flusso d'aria a variazione continua nella seduta e nello schienale.

*Full lymph-draining and invigorating massage by air flux in the back and in the seat.*

*Massage total lympho-drainant par flux d'air à variation continue sur l'assise et sur le dossier.*

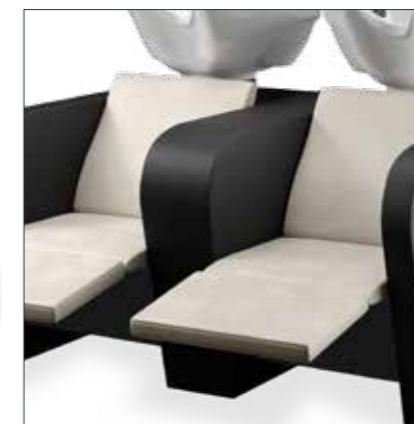
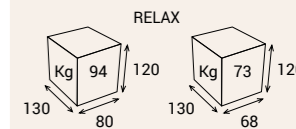
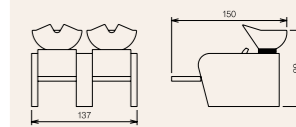
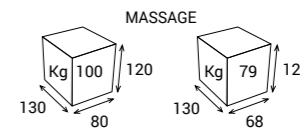
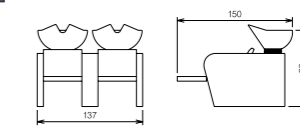

Art. 8070

# ROYAL WASH

VEZZOSIEMPORIO

Struttura imbottita e ricoperta in skai, colore tappezzeria a scelta, lavello basculante, porta shampoo posteriore.

Frame guilted and covered with skai, tilting white basin, shampoo holder on the backside, upholstery in skai.

Structure rembournée et recouverte en skai, cuvette blanche basculante, porte shampoings posterieur, tapisserie en skai.

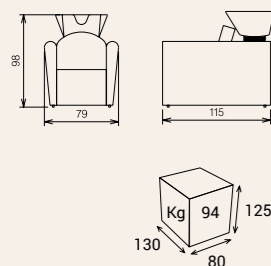

# ROYAL WASH relax

Art. 8075

VEZZOSIEMPORIO

Poggiagambe regolabile elettricamente, tappezzeria in skai.

Adjusting leg-rest by electronics, upholstery in skai.

Appui-jambes réglable par l'électronique, tapisserie en skai.



## Optional ONE TOUCH

Alzagambe ad impulso automatico.

Automatic impulse leg lifters.

Leviers de jambes à impulsion automatique.



## ROYAL WASH massage

Art. 8077 AIR MASSAGE

Massaggio totale linfodrenante a flusso d'aria a variazione continua nella seduta e nello schienale.

Full lymph-draining and invigorating massage by air flux in the back and in the seat.

Massage total lympho-drainant par flux d'air à variation continue sur l'assise et sur le dossier.

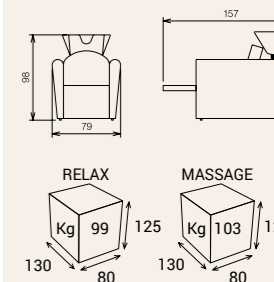



Art. 8080

# JO-WASH

VEZZOSIEMPORIO

Struttura imbottita e ricoperta in skai, colore tappezzeria a scelta, livello basculante, porta shampo posteriore, bracciolo removibile per garantire l'accesso facilitato alle persone a mobilità ridotta.

*Frame quilted and covered with skai, tilting white basin, shampoo holder on the backside, removable armrest to facilitate the access to persons with reduced mobility, upholstery in skai.*

*Structure rembournée et recouverte en skai, cuvette blanche basculante, porte shampoings posterieur, accoudoir amovible pour faciliter l'access aux personnes à mobilité reduite, tapisserie en skai.*



## UTILITY Art. 3815

Utility in acciaio inox con vaschetta in ceramica bianca, non incluso

*Utility in steel with pottery basin white, not included.*

*Utility en acier inox, basin en ceramique blanc, pas inclus.*

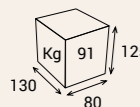
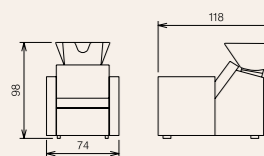
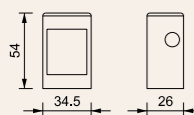

Bracciolo removibile per garantire l'accesso facilitato alle persone a mobilità ridotta.  
*Removable armrest to facilitate the access to persons with reduced mobility.*  
*Accoudoir amovible pour faciliter l'access aux personnes à mobilité reduite.*



# JO-WASH relax

Art. 8085

VEZZOSIEMPORIO

Poggiagambe regolabile elettricamente, tappezzeria in skai.

*Adjusting leg-rest by electronics, upholstery in skai.*

*Appui-jambes réglable par l'electronique, tapisserie en skai.*



## Optional ONE TOUCH

Alzagambe ad impulso automatico.

*Automatic impulse leg lifters.*

*Leviers de jambes à impulsion automatique.*



## JO-WASH massage Art. 8087 AIR MASSAGE

Massaggio totale linfodrenante a flusso d'aria a variazione continua nella seduta e nello schienale.

*Full lymph-draining and invigorating massage by air flux in the seat and in the seat.*

*Massage total lymph-drainant par plus d'air a variation continue sur l'assise et sur le dossier.*

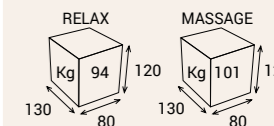
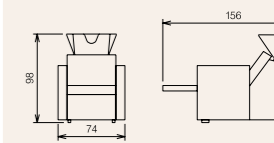



Art. 3170

# XILEMA wash

Struttura imbottita e ricoperta in skai, braccioli con protezione in acciaio, lavello bianco basculante, flessibile antigoccia, tappezzeria in skai.

Frame quilted and covered with skai, armrest with protection in steel, tilting white basin, flexible pipe with antidrop system, upholstery in skai.

Structure rembournee et recouverte en skai, protection accoudoirs en acier, cuvette basculante blanche, flexible antiencoulement, tapiserie en skai.

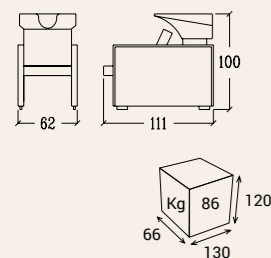

## XILEMA relax

Art. 3180

Poggiagambe regolabile elettricamente per servizio relax.

Wash unit with electronic leg rest.

Repose pieds relax réglable par l'électronique.



## XILEMA airwash

Art. 3175



Massaggio totale linfodrenante a flusso d'aria a variazione continua su tutto il corpo.

Full lymph-draining and invigorating massage by air flux over the whole body.

Massage total lymph-drainant par flux d'air a variation continue sur tout le corps

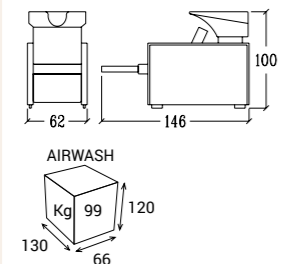
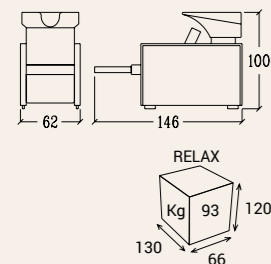

# KUBIK flat e relax flat



Art. 3197

# KUBIK flat

Struttura imbottita e ricoperta in skai, livello bianco basculante, tappezzeria in skai.

*Frame guilted and covered with skai, tilting white basin, upholstery in skai.*

*Structure rembournee et recouverte en sky, cuvette basculante blanche, tapisserie en skai.*



## UTILITY

Art. 3570

Utility in acciaio, non incluso.

*Utility in stee, not included.*

*Utility en acie, pas inclus.*



## PANNELLO

Art. 3575

Pannello copritubi in materiale poliuretano color grigio, non incluso.

*Panel for covering the pipes in polyurethane colour grey, not included.*

*Panneau pour couvrir les tujaux en materiel poliurethane couleur gris, non inclus.*

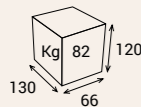
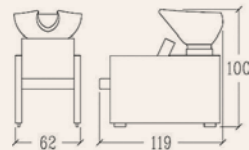

# KUBIK relax flat

Art. 3199

Poggiagambe regolabile elettricamente, tappezzeria in skai.

*Adjusting leg-rest by electronics, upholstery in skai.*

*Appui-jambes réglable par l'electronique, tapisserie en skai.*



## PANNELLO

Art. 3575

Pannello copritubi in materiale poliuretano color grigio, non incluso.

*Panel for covering the pipes in polyurethane colour grey, not included.*

*Panneau pour couvrir les tujaux en materiel poliurethane couleur gris, non inclus.*

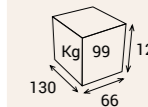
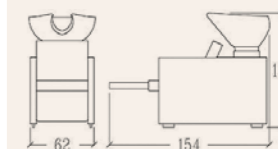



POLTRONE LAVORO  
rotating chairs  
fauteuils tournants





Art. 9856

# CURVE poltrona lavoro

**Con pompa.  
With pump.  
Avec pompe.**

**CURVE**  
by Santachiara

Base acciaio lucido, struttura in vetroresina bianca lucidata, con pompa idraulica, tappezzeria in skai.

*Shine steel base, frame in shine white fiberglass, with hydraulic pump, upholstery in skai.*

*Base en acier brillant, structure en fibre de verre couleur blanc brillant, avec pompe hydraulique, tapisserie en skai.*



Art. 9855

**Senza pompa.  
Without pump.  
Sans pompe.**

Base acciaio lucido, struttura in vetroresina bianca lucidata, tappezzeria in skai.

*Shine steel base, frame in shine white fiberglass, upholstery in skai.*

*Base en acier brillant, structure en fibre de verre couleur blanc brillant, tapisserie en skai.*

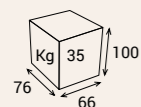
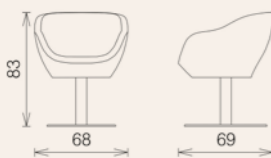

# CURVE poltrona lavoro

Art. 9851

**CURVE**  
by Santachiara

**Con pompa.  
With pump.  
Avec pompe.**

Base acciaio lucido, struttura in vetroresina bianca lucidata, con pompa idraulica, tappezzeria in skai.

*Shine steel base, frame in shine white fiberglass, with hydraulic pump, upholstery in skai.*

*Base en acier brillant, structure en fibre de verre couleur blanc brillant, avec pompe hydraulique, tapisserie en skai.*



Art. 9850

**Senza pompa.  
Without pump.  
Sans pompe.**

Base acciaio lucido, struttura in vetroresina bianca lucidata, tappezzeria in skai.

*Shine steel base, frame in shine white fiberglass, upholstery in skai.*

*Base en acier brillant, structure en fibre de verre couleur blanc brillant, tapisserie en skai.*

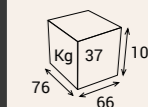
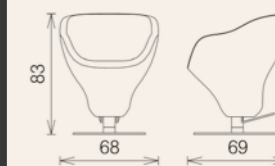



# FUNKY

Art. 9315

Struttura completamente rivestita in skai.

*Structure completely upholstered in skai.*

*Structure complètement couverte en skai.*

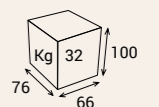
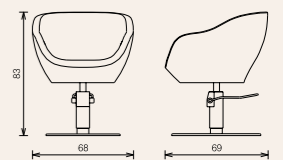



## Art. 9310

# S-CHAIR

Struttura in metallo  
interamente ricoperta  
in skai.

*Metal structure completely  
covered in skai.*

*Structure metallique  
completement couvert en  
skai.*

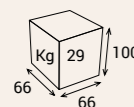
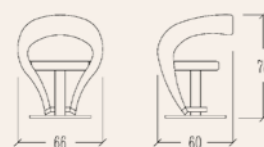

# POD

## Art. 9010



**Senza pompa.**  
**Without pump.**  
**Sans pompe.**

Base in acciaio lucido,  
struttura in materiale  
poliuretano bianco,  
tappetzeria in skai.

*Shine steel base, frame in  
white polyurethane material,  
upholstery in skai.*

*Base en acier brillant,  
structure en materiel  
poliurethane blanc, tapisserie  
en skai.*



## Art. 9015

**Con pompa.**  
**With pump.**  
**Avec pompe.**

Base in acciaio lucido,  
struttura in materiale  
poliuretano, tappetzeria  
in skai.

*Shine steel base, frame in  
white polyurethane material,  
upholstery in skai.*

*Base en acier brillant,  
structure en materiel  
poliurethane blanc, tapisserie  
en skai.*

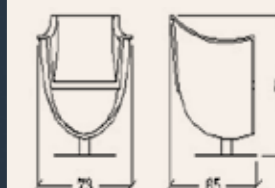



# LUPE

Art. 1300

Struttura in acciaio verniciato, tappezzeria in skai.

*Frame in painted steel, upholstery in skai.*

*Structure en acier verni, tapisserie en skai.*

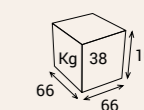
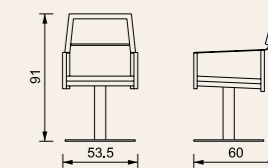

Art. 1310

# DORA

Struttura in poliuretano espanso, tappezzeria in skai.

Frame in moulded expanded polyurethane, upholstery in skai.

Structure en polyurethane, tapisserie en skai.

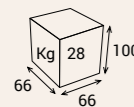
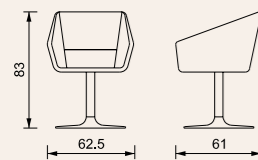

# CARNABY

Art. 1396

Imbottitura in poliuretano espanso, tappezzeria in skai.

Structure in polyurethane material, upholstery in skai.

Structure en materiel polyrethane, tapisserie en skai.

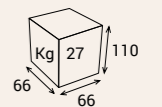
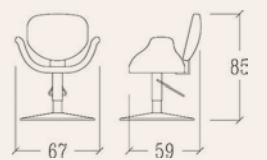



Art. 9311

# EPOQUE

VEZZOSIEMPORIO

Struttura completamente rivestita in skai, colore tappezzeria a scelta.

Structure completely covered in skai at choice.

Structure completement couverte en skai à choix.

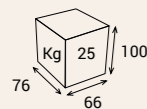
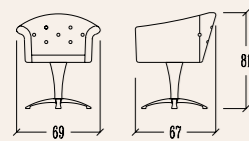

# TRAFALGAR

Art. 8175

VEZZOSIEMPORIO

Struttura in multistrato di faggio, imbottitura in poliuretano espanso, rivestita in skai.

Frame in multi-ply beech, covered by mouled polyurethane, upholstery in skai.

Structure multicouche de hêtre, rembourrage en polyurethane, tapisserie en skai.

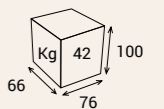
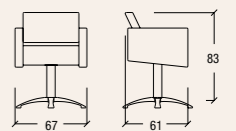

## Art. 1398

# PICCADILLY

Imbottitura in poliuretano espanso, tappezzeria in skai.

*Structure in polyurethane material, upholstery in skai.*

*Structure en materel polyrethane, tapisserie en skai.*

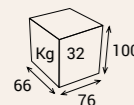
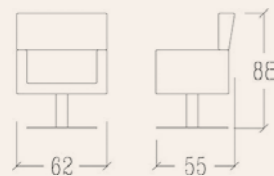

# GAGA

## Art. 1338

Struttura completamente rivestita in skai.

*Structure completely upholstered in skai.*

*Structure completement couverte en skai.*

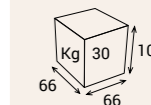
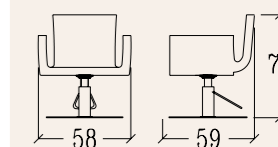

Art. 1397

# OXFORD

Imbottitura in poliuretano espanso, tappezzeria in skai.

Structure in polyurethane material, upholstery in skai.

Structure en materel polyrethane, tapisserie en skai.

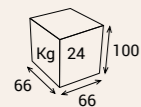
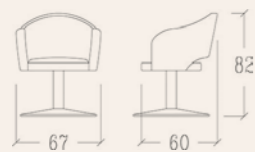

# DEVIL

Art. 1327

Struttura completamente rivestita in skai.

Structure completely upholstered in skai.

Structure completement couverte en skai.

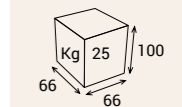
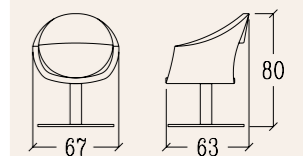





# UMA

## Art. 1350

Struttura in poliuretano espanso con inserto interno in acciaio, tappezzeria in skai.

*Frame in mouled expanded polyurethane with steel frame, upholstery in skai.*

*Structure en polyurethane avec structure en acier, tapisserie en skai.*

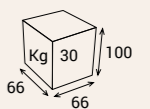
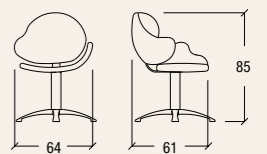

Art. 1340

# SAHARA

Struttura completamente rivestita in skai.

*Structure completely upholstered in skai.*

*Structure completement couverte en skai.*

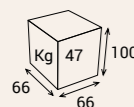
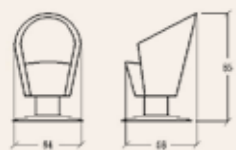

# ROYAL

Art. 8125

**VEZZOSI**EMPORIO

Struttura completamente rivestita in skai, colore tappezzeria a scelta.

*Structure completely covered in skai at choice.*

*Structure completement couverte en skai à choix.*

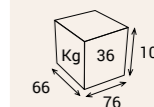
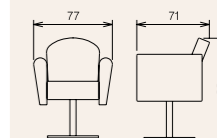

Art. 8145

# MEG

VEZZOSIEMPORIO

Struttura in poliuretano espanso con inserto interno in acciaio, tappezzeria in skai.

Frame in moulded expanded polyurethane with steel frame, upholstery in skai.

Structure en polyurethane avec structure en acier, tapisserie en skai.

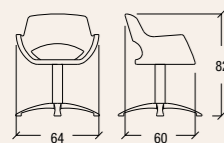

# AVATAR

Art. 9308

Struttura in metallo interamente ricoperta in skai.

Metal structure completely covered in skai.

Structure metallique completement couvert en skai.

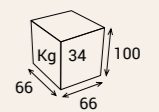
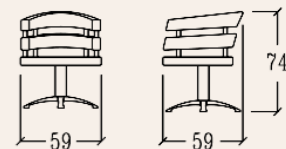

# KELLY

Art. 8167

Struttura in multistrato di faggio, imbottitura in poliuretano espanso, braccioli in tubolare d'acciaio finitura lucida.

Frame in multi-ply beech, covered by moulded polyurethane, upholstery in skai, armrest in chromed glossy steel.

Structure pan multicouche, hêtre rembourrage en polyurethane, tapisserie en skai, accoudoirs acier chromé brillant.

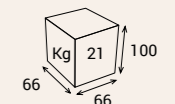
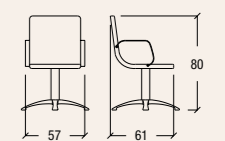



Art. 8146

# VIKY

VEZZOSIEMPORIO

Struttura in multistrato, tappezzeria in skai, colore a scelta.

Frame in multi-ply, upholstery in skai at choice.

Structure en multicouche, tapissérie en skai à choix.

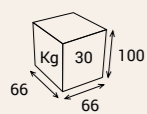
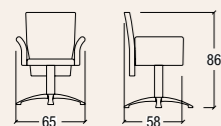

Art. 8148

# SCARLETT

VEZZOSIEMPORIO

Struttura completamente rivestita in skai.

Structure completely upholstered in skai.

Structure completement couverte en skai.

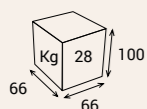
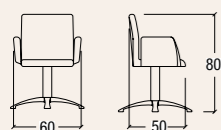

# APPLE

Art. 8136

VEZZOSIEMPORIO

Struttura in acrilico trasparente, cuscino in skai colore a scelta.

Frame in transparent acrylic, seat in skai colour at choice.

Structure en acrilic ransparent, assise en skai couleur à choix.

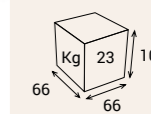
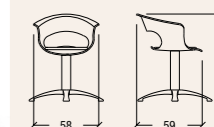

# XILEMA chair

Art. 1399

Base e braccioli in acciaio lucido, tappezzeria in skai.

Base and armrest in shine steel, upholstery in skai.

Base et accoudoirs en acier brillant, tapissérie en skai.

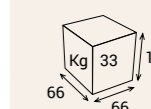
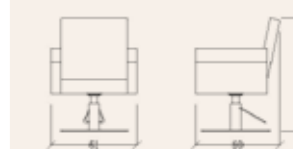

Art. 1395

# ALLISON

Base e braccioli in acciaio lucido, tappezzeria in skai.

*Base and armrest in shine steel, upholstery in skai.*

*Base et accoudoirs en acier brillant, tapisserie en skai.*

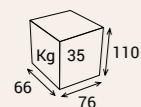

# FRIDA

Art. 1320

Struttura in metallo verniciato, tappezzeria in skai.

*Frame in painted metal, upholstery in skai.*

*Structure en metal verni, tapisserie en skai.*

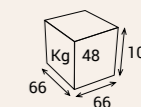
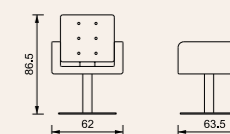

# Art. 1321

# EVA

Poggiapiede in metallo verniciato, poggiatesta regolabile, schienale reclinabile, tappezzeria in skai.

*Foot-rest in painted metal, adjustable headrest, reclining backrest, upholstery in skai.*

*Repose pieds en metal verni, appuie tete réglable, dossier inclinable, tapisserie en skai.*

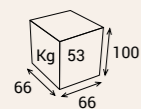
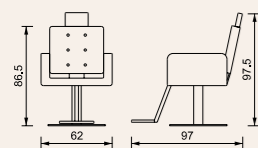

# GINGER

# Art. 1325

Struttura completamente rivestita in skai.

*Structure completely upholstered in skai.*

*Structure complètement couverte en skai.*

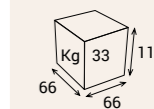



Art. 1326

# GINGERMAN

Struttura rivestita in skai, poggiatesta regolabile, schienale reclinabile, poggipiedi incorporato.

*This structure is upholstered with skai fabrics, adjustable headrest, reclining backrest, foot/rest incorporated.*

*Structure et revêtement en skai, appuie-tete réglable, dossier inclinable, repose/pieds incorporee.*

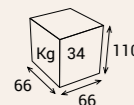
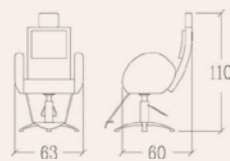

# ADAM

Art. 1322

Struttura in metallo verniciato, poggiatesta regolabile, schienale e poggipiedi reclinabili.

*Frame in painted metal, adjustable headrest, backrest and foot rest reclining.*

*Structure en metal verni, appuie tete réglable, dossier et repose pieds inclinables.*

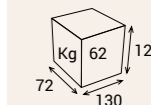
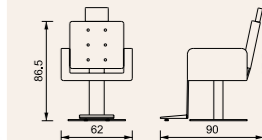



# DANDY

Art. 8169

VEZZOSIEMPORIO



Poltrona barbiere con carter laterale e basamento colore bianco lucido o nero lucido, schienale reclinabile, poggiatesta e poggiaiedi regolabili, colore tappezzeria a scelta.

*Barber chair, sides and foot white or black, adjusting headrest and leg rest, upholstery in skai at choice.*

*Barber fauteuil, côtés latérales et pied blanc ou noir brillant, dossier reclinable, repose tête et repose pieds réglables, tapisserie en skai couleurs à choix.*

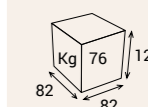
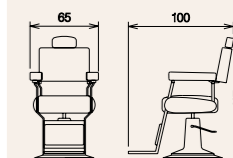



Art. 9314

# NEWTON PLUS

Struttura rivestita in skai, colore a scelta, tappezzeria decorata tipo trapunta poggiatesta regolabile, schienale reclinabile, poggipiedi incorporato.

*This structure is upholstered with skai fabrics at choice, upholstery embroidered, adjustable headrest, reclining backrest, foot/rest incorporated.*

*Structure et revêtement en skai couleurs à choix, tapisserie brodée, appuie-tête réglable, dossier inclinable, repose-pieds incorporee.*

VEZZOSIEMPORIO

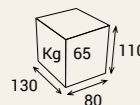
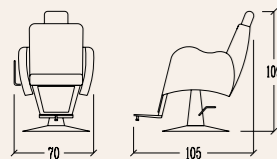

# CASANOVA

Art. 9313

VEZZOSIEMPORIO



Poltrona barbiere schienale reclinabile, poggiatesta e poggipiedi regolabili, finiture in fusione di alluminio e particolari acciaio inox, colore skai a scelta dal nostro campionario.

*Barber chair inclining bac adjusting headrest and leg rest aluminium and stainless steel, finishes upholstery in skai as for our shample book.*

*Fauteuil barbier dossier inclinable repose tete et repose pieds reglables finissage en aluminium, details en acier inox, tapisserie en skai couleur a choix selon notre echantillon de skai.*

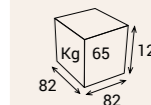
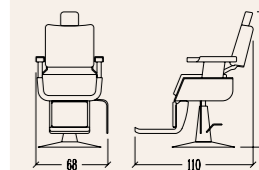





03.

POLTRONE ATTESA  
waiting chairs  
fauteuils attente





# CURVE panchetta attesa

Art. 9872

**CURVE**  
by Santachiara

Struttura completamente rivestita in skai.

*Structure completely upholstered in skai.*

*Structure complètement couverte en skai.*

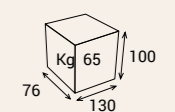

Art. 2245

# LOLITA

Struttura in laminato  
plastico, tappezzeria in skai.

*Structure in plastic laminated,  
uphostery in skai.*

*Structure en stratifié.  
Tapisserie en skai.*

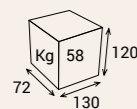
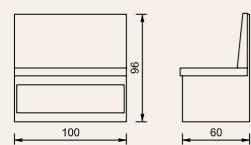

# LITTLE SHINE

Art. 2790

Struttura in laminato  
plastico, portariviste  
incorporato, tappezzeria  
in skai.

*Structure in plastic  
laminated, news paper holder  
incorporated, uphostery  
in skai.*

*Structure en stratifié,  
porte revues incorporees.  
Tapisserie en skai.*

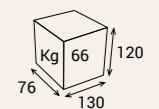



Art. 2985

# DUBAI

Struttura in laminato  
plastico, bottoni in cristallo  
brillante, tappezzeria in skai

*Structure in plastic laminated,  
botton in crystal brilliant,  
uphostery in skai*

*Structure en stratifié,  
touche en crystal brillant.  
Tapisserie en skai*

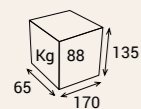
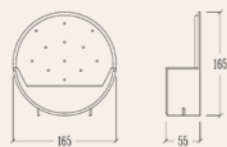

# FUSION

Art. 5800

Struttura interamente  
ricoperta in skai.

*Structure totally upholstered  
with skai.*

*Structure entièrement  
revetue en skai.*

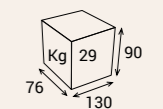
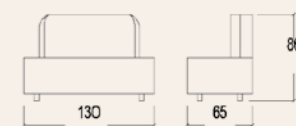

Art. 2160

# NAPOLEONE waiting

Struttura interamente ricoperta in skai.

Structure totally upholstered with skai.

Structure entièrement revetue en skai.

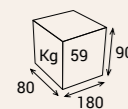

# WHITE

Art. 2975  
Art. 2970

Struttura interamente ricoperta in skai.

Structure totally upholstered with skai.

Structure entièrement revetue en skai.



Art. 2975

Art. 2970

Art. 2975

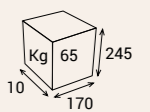
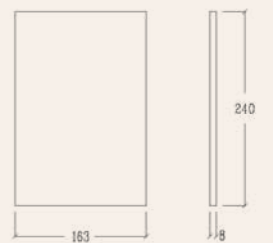

Art. 2970

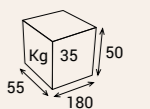
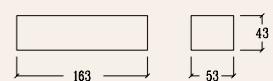

### Art. 2090

# XILEMA waiting

Struttura in laminato plastico, angoli in acciaio, tappezzeria in skai.

*Frame in plastic laminated, angulars in shine steel, upholstery in skai.*

*Structure en stratifié, angulaires en acier brillant, tapisserie en skai.*

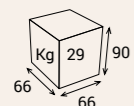

### Art. 2091

**Portacasco.  
Dryer-holder.  
Porte casque.**

Struttura in laminato plastico, angoli in acciaio, tappezzeria in skai.

*Frame in plastic laminated, angulars in shine steel, upholstery in skai.*

*Structure en stratifié, angulaires en acier brillant, tapisserie en skai.*

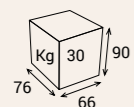
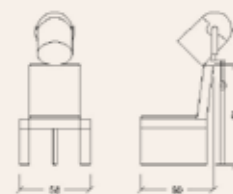

# XILEMA sofà

### Art. 2095

Struttura in laminato plastico, angoli in acciaio, tappezzeria in skai.

*Frame in plastic laminated, angulars in shine steel, upholstery in skai.*

*Structure en stratifié, angulaires en acier brillant, tapisserie en skai.*

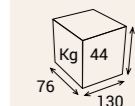

### Art. 2096

**Portacasco.  
Dryer-holder.  
Porte casque.**

Struttura in laminato plastico, angoli in acciaio, tappezzeria in skai.

*Frame in plastic laminated, angulars in shine steel, upholstery in skai.*

*Structure en stratifié, angulaires en acier brillant, tapisserie en skai.*

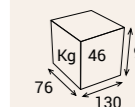
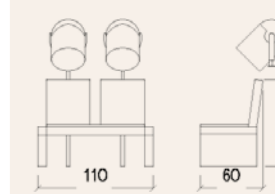





# POD waiting

Art. 9020



Base in acciaio lucido, struttura in materiale poliuretano bianco, tappezzeria in skai.

*Shine steel base, frame in white polyurethane material, upholstery in skai.*

*Base en acier brillant, structure en materiel poliurethane blanc, tapisserie en skai.*

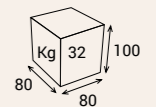
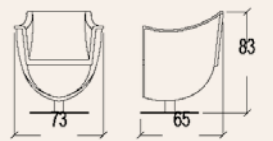

Art. 9025

**Portacasco.  
Dryer-holder.  
Porte casque.**

Base in acciaio lucido, struttura in materiale poliuretano bianco, tappezzeria in skai.

*Shine steel base, frame in white polyurethane material, upholstery in skai.*

*Base en acier brillant, structure en materiel poliurethane blanc, tapisserie en skai.*

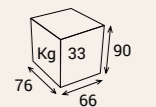
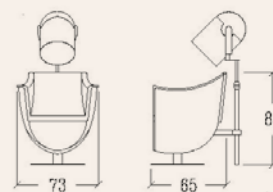

Art. 2240

# GOSPEL

Struttura interamente ricoperta in skai.

Structure totally upholstered with skai.

Structure entièrement revetue en skai.

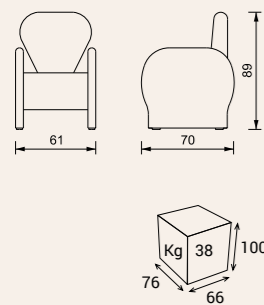

Art. 2243

**Portacasco.  
Dryer-holder.  
Porte casque.**

Struttura interamente ricoperta in skai.

Structure totally upholstered with skai.

Structure entièrement revetue en skai.

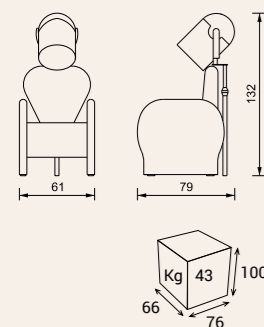

# GOSPEL sofà

Art. 2241

Struttura interamente ricoperta in skai.

Structure totally upholstered with skai.

Structure entièrement revetue en skai.

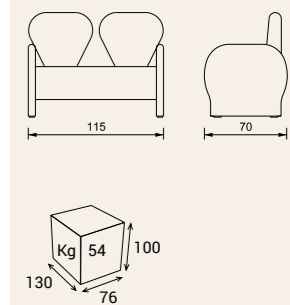

Art. 2244

**Portacasco.  
Dryer-holder.  
Porte casque.**

Struttura interamente ricoperta in skai.

Structure totally upholstered with skai.

Structure entièrement revetue en skai.

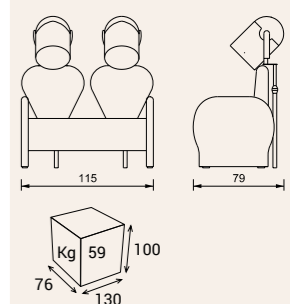

Art. 2280

# GINEVRA

Struttura interamente ricoperta in skai.

Structure totally upholstered with skai.

Structure entièrement revetue en skai.

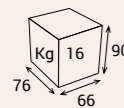
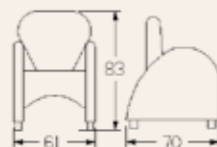

Art. 2281

Portacasco.  
Dryer-holder.  
Porte casque.

Struttura interamente ricoperta in skai.

Structure totally upholstered with skai.

Structure entièrement revetue en skai.

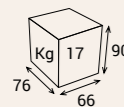
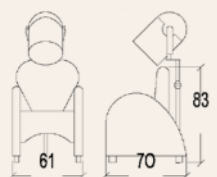

# GINEVRA sofà

Art. 2282

Struttura interamente ricoperta in skai.

Structure totally upholstered with skai.

Structure entièrement revetue en skai.

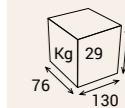
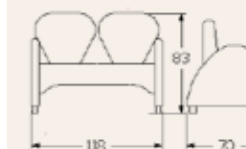

Art. 2283

Portacasco.  
Dryer-holder.  
Porte casque.

Struttura interamente ricoperta in skai.

Structure totally upholstered with skai.

Structure entièrement revetue en skai.

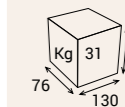
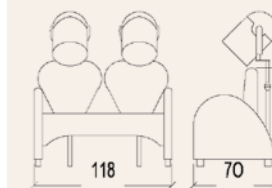



Art. 2130

# STAR

Sostegno schienale in metallo verniciato, piedi in alluminio, tappezzeria in skai.

Back holder in painted metal, feet in aluminium, upholstery in skai.

Support du dossier en metal verni, pieds en aluminium, tapisserie en skai.

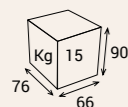

Art. 2135

# STAR3

Sostegno schienale in metallo verniciato, piedi in alluminio, tappezzeria in skai.

Back holder in painted metal, feet in aluminium, upholstery in skai.

Support du dossier en metal verni, pieds en aluminium, tapisserie en skai.

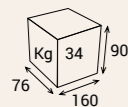
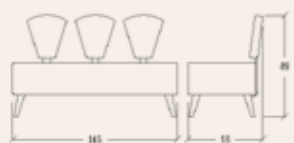

# IL RETTANGOLO

Art. 2900

Puff 2 posti, piedi in alluminio, tappezzeria in skai.

Pouf 2 places, feet in aluminium, upholstery in skai.

Pouf 2 places, pieds en aluminium, tapisserie en skai.

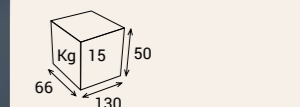
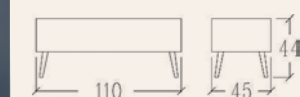

# IL BACELLO

Art. 2950

Puff 2 posti, piedi in alluminio, tappezzeria in skai.

Pouf 2 places, feet in aluminium, upholstery in skai.

Pouf 2 places, pieds en aluminium, tapisserie en skai.

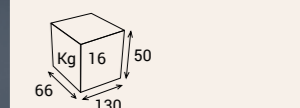
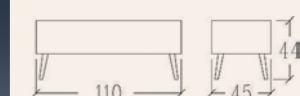

# QUADROTTO

Art. 2800

Puff, piedi in alluminio, tappezzeria in skai.

Pouf, feet in aluminium, upholstery in skai.

Pouf, pieds en aluminium, tapisserie en skai.

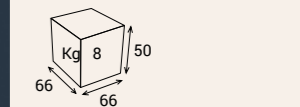
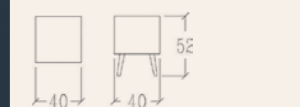



# ROYAL waiting

Art. 8320

VEZZOSIEMPORIO

Struttura imbottita e completamente rivestita in skai, colore tappezzeria a scelta.

*Structure completely covered in skai at choice.*

*Structure completement couverte en skai à choix.*

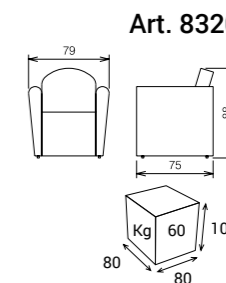

Art. 8321  
Portacasco.  
Dryer-holder.  
Porte casque.

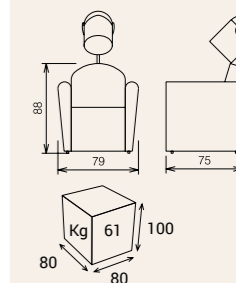

# ROYAL sofà

Art. 8325

Struttura imbottita e completamente rivestita in skai, colore tappezzeria a scelta.

*Structure completely covered in skai at choice.*

*Structure completement couverte en skai à choix.*

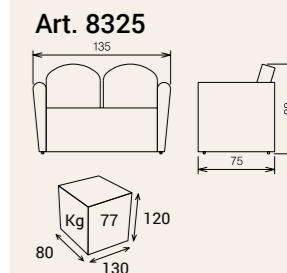

Art. 8326  
Portacasco.  
Dryer-holder.  
Porte casque.

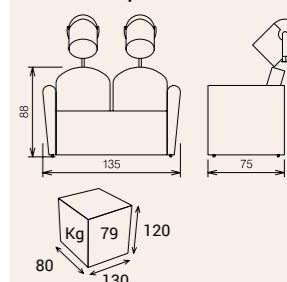



Art. 8300

# SWEET

VEZZOSIEMPORIO

Imbottitura in poliuretano espanso, struttura interna in acciaio, tappezzeria in skai.

Frame in mouled expanded polyurethane with steel frame, upholstery in skai.

Structure en polyurethane avec inside structure en acier, tapisserie en skai.



Art. 8301  
Portacasco.  
Dryer holder-fauteuils.  
Porte casque.

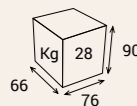
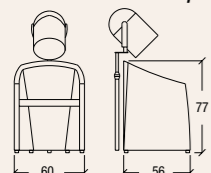

Art. 8300

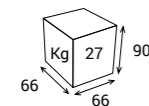
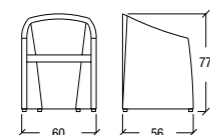

Art. 8335

# BEVERLY

VEZZOSIEMPORIO

Struttura imbottita e completamente ricoperta in skai, colore tappezzerai a scelta, zoccolo in laminato.

Structure completely covered in skai at choice, plinth in laminated.

Structure completement couverte en skai à choix, socle en stratifié.



Art. 8336  
Portacasco.  
Dryer-holder.  
Porte casque.

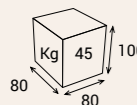
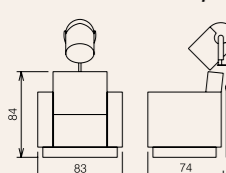

Art. 8335

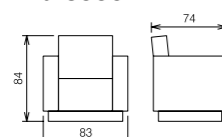

# FEEL

Art. 8310

VEZZOSIEMPORIO

Struttura in agglomerato, imbottitura in poliuretano espanso, tappezzeria in skai.

Frame in agglomerate wood, padding in polyurethane, upholstery in skai.

Structure en bois agglomeré, rembourrage en polyurethane, tapisserie en skai.

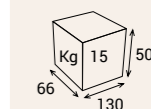
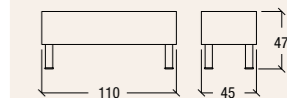

# SINGLE

Art. 8305

VEZZOSIEMPORIO

Struttura in agglomerato, imbottitura in poliuretano espanso, tappezzeria in skai.

Frame in agglomerate wood, padding in polyurethane, upholstery in skai.

Structure en bois agglomeré, rembourrage en polyurethane, tapisserie en skai.

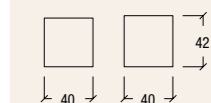





POSTI LAVORO  
styling units  
coiffeuses



Art. 9828

# CURVE postazione doppia

**CURVE**  
by Santachiara

Top in laminato plastico bianco lucido, laterali in materiale poliuretano bianco, poggiatesta acciaio, frontale a listelli con illuminazione incorporata.

*Top in shine white plastic laminate, sides in white polyurethane material, foot-rest in steel, front in wood listels with lighting incorporated.*

*Top en stratifié blanc brillant cotes en materiel poliurethane blanc, repose-pieds en acier, frontal en lamelles de bois avec éclairage incorpore.*

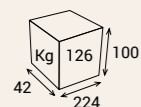
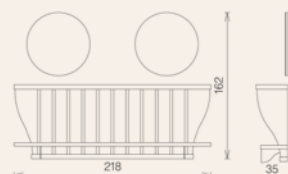

# CURVE postazione doppia

**CURVE**  
by Santachiara

Art. 9829

Top in laminato plastico bianco lucido, laterali in materiale poliuretano bianco, poggiatesta acciaio, frontale a listelli con illuminazione incorporata.

*Top in shine white plastic laminate, sides in white polyurethane material, foot-rest in steel, front in wood listels with lighting incorporated.*

*Top en stratifié blanc brillant cotes en materiel poliurethane blanc, repose-pieds en acier, frontal en lamelles de bois avec éclairage incorpore.*

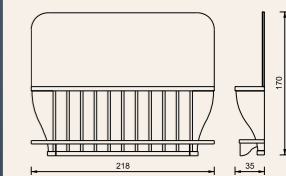





# CURVE postazione 4 posti

Art. 9836

**CURVE**  
by Santachiara

Top in laminato plastico bianco lucido, laterali in materiale poliuretano bianco, poggiatesta acciaio, frontale a listelli con illuminazione incorporata.

*Top in shine white plastic laminate, sides in white polyurethane material, foot-rest in steel, front in wood listels with lighting incorporated.*

*Top en stratifié blanc brillant cotes en materiel poliurethane blanc, repose-pieds en acier, frontal en lamelles de bois avec éclairage incorporé.*

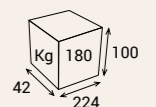
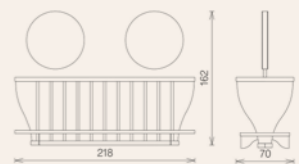



Art. 9826

# CURVE postazione

Con porta phon.  
With dryer holder.  
Avec porta sechoir.

**CURVE**  
by Santachiara

Struttura in materiale poliuretano bianco, top e poggiatesta in acciaio, specchio rettangolare con illuminazione a led incorporata, portaphon e porta spazzole estraibili.

Frame in white polyurethane material, top and foot rest in shine steel, rectangular mirror with decorative led, with extracting dryer and hair brushes holder.

Structure en materiel poliurethane blanc, top et repose-pieds en acier brillant, miroir rectangulaire avec eclairage à led incorporé, avec portesechoir et portebross extraibles.



Art. 9825

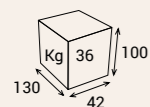
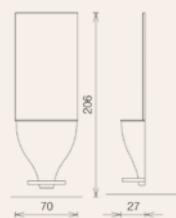

# CURVE postazione

Art. 9821

**CURVE**  
by Santachiara

Struttura in materiale poliuretano bianco, top e poggiatesta in acciaio, specchio tondo con illuminazione a led incorporata.

Frame in white polyurethane material, top and foot rest in shine steel, round mirror with decorative led.

Structure en materiel poliurethane blanc, top et repose-pieds en acier brillant, miroir rond avec eclairage à led incorporé.

Art. 9822

Con porta phon.  
With dryer holder.  
Avec porta sechoir.

Portaphon e porta spazzole estraibili.

Extracting dryer and brushes holder.

Portesechoir et portebross extraibles.

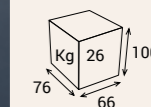
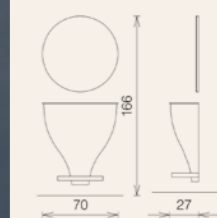
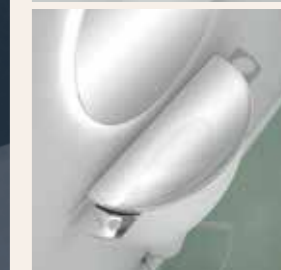
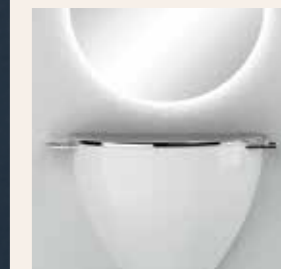



Art. 9338

# NEW AGE wall

Struttura in laminato plastico, poggiatesta in acciaio, specchiera con nicchie incorporate.

*Structure in plastic laminated, foot rest in steel, looking glass with niches incorporated.*

*Structure en stratifié, repose pieds en acier, glace avec niches incorporées.*

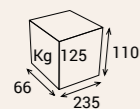
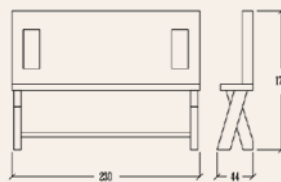

# NEW AGE island

Art. 9339

Struttura in laminato plastico, poggiatesta in acciaio, specchiera con nicchie incorporate.

*Structure in plastic laminated, foot rest in steel, looking glass with niches incorporated.*

*Structure en stratifié, repose pieds en acier, glace avec niches incorporées.*

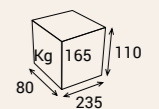
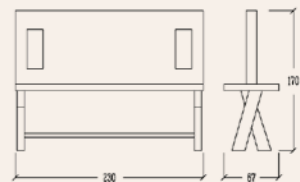

Art. 4039

# FELIPE

Struttura in laminato,  
completo di specchi e  
poggiapedali.

*Structure in laminated  
mirrors and foot rest  
included.*

*Structure en stratifié,  
miroirs  
et repose pieds inclus.*

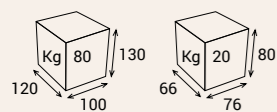
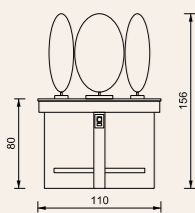

# EDEN





Art. 8275

# EDEN

Centrale bifacciale, struttura in laminato acciaio, base acciaio lucido e supporto in tubo acciaio cromato lucido. Poggiapiedi incluso. Poggiapiedi indicati tipo art. 7300 o 7340.  
**Vedi listino.**

*Free standing double styling unit, structure en shine steel laminate, base in shine steel, stem in chromium plated steel. Foot rest included. Foot-rest indicated art. 7300 or 7340. See price list.*

*Centrale double face, structure en stratifié' acier brillant, base en acier brillant, tige en acier chrome'. Repose pieds inclus. Repose pieds indiqué art. 7300 ou 7340.  
**Voir la liste de prix.***

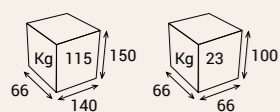
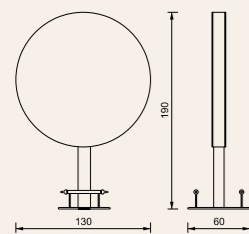

# EDEN +

Art. 8275P

Centrale bifacciale, struttura in laminato acciaio, base acciaio lucido e supporto in tubo acciaio cromato lucido. Piano lavoro in legno laccato. Poggiapiedi incluso. Poggiapiedi indicati tipo art. 7300 o 7340.  
**Vedi listino.**

*Free standing double styling unit, structure en shine steel laminate, base in shine steel, stem in chromium plated steel. Top in laquered wood. Foot rest included. Foot-rest indicated art. 7300 or 7340.  
**See price list.***

*Centrale double face, structure en stratifié' acier brillant, base en acier brillant, tige en acier chrome'. Tablette en bois laqué. Repose pieds inclus. Repose pieds indiqué art. 7300 ou 7340. rectangulaire.  
**Voir la liste de prix.***

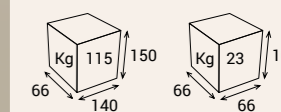
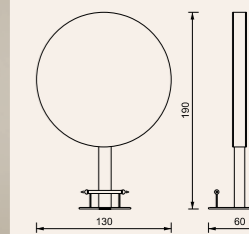

# CLEOPATRA





Art. 4100

# CLEOPATRA wall

Posto lavoro con illuminazione incorporata, contorno in plexiglass serigrafato, base in acciaio lucido, supporto in tubo acciaio cromato. Poggiapiedi non incluso.

*Styling unit with lighting incorporated, outline in plexiglass with decoration, base in shine steel, tube in chromium plated steel. Foot rest not included.*

*Coiffeuse avec illumination incorporee, contour en plexiglass decore' base en acier brillant, tube en acier chrome'. Repose pieds pas inclus.*

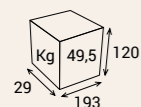
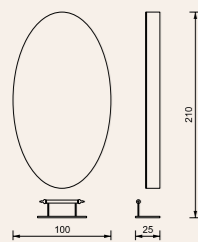

# CLEOPATRA

Art. 4105

Centrale bifacciale, illuminazione incorporata, contorno in plexiglass serigrafato, base in acciaio lucido, supporto in tubo acciaio cromato. Poggiapiedi incluso. Poggiapiedi indicati tipo art. 7300 o 7340.

**Vedi listino.**

*Free standing double styling unit, lighting incorporated, outline in plexiglass with decoration, base in shine steel, tube in chromium plated steel. Foot rest included. Foot-rest indicated art. 7300 or 7340.*

**See price list.**

*Centrale double face, illumination incorporee, contour en plexiglass decore' base en acier brillant, tube en acier chrome'. Repose pieds inclus. Repose pieds indique' art. 7300 ou 7340.*

**Voir la liste de prix.**

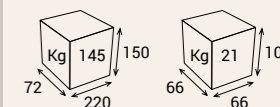
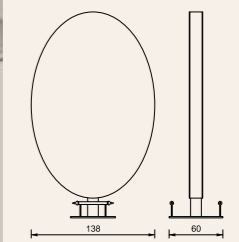



Art. 8246

# GIOTTO

VEZZOSIEMPORIO

Centrale bifacciale, base in cemento fuso, struttura in laminato bianco e supporto specchio in metallo verniciato bianco.

*Free standing double styling unit, basement in cement, structure in white laminate and mirror support in white painted metal.*

*Centrale double face, base en beton, structure en stratifié blanc, support miroir en metal verni blanc.*

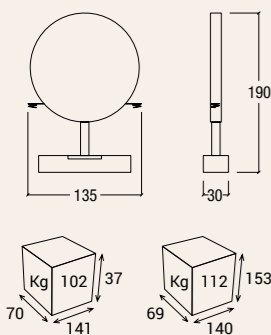

# GIOTTO+

Art. 8247

VEZZOSIEMPORIO

Centrale bifacciale, base in cemento fuso, struttura in laminato bianco e supporto specchio in metallo verniciato bianco. Piano lavoro in legno laccato.

*Free standing double styling unit, basement in cement, structure in white laminate and mirror support in white painted metal. Top in laquered wood.*

*Centrale double face, base en beton, structure en stratifié blanc, support miroir en metal verni blanc. Tablette en bois laqué.*

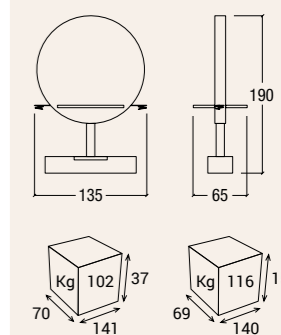



# S-WALL

Art. 5150

Struttura in poliuretano rigido trattato con vernice antimacchia, poggiatesta incluso.

*Structure in polyurethane treated with stainproof, footrest included.*

*Structure en materiel poliurethane traite' avec peinture anti tache, repose pieds inclus.*

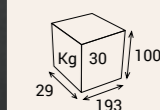
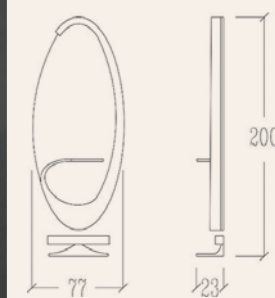

## Art. 5180

# POLARIS

Tavolo centrale 4 posti lavoro, struttura in laminato plastico, poggiatesta in acciaio.

*Table 4 places, structure in plastic laminated, foot rest in steel.*

*Table 4 places, structure en stratifié, repose pieds en acier.*

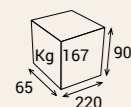
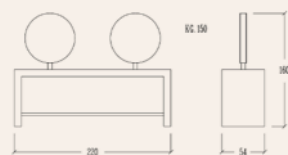

# POLARIS +

## Art. 5181

Tavolo centrale 4 posti lavoro, struttura in laminato plastico, poggiatesta in acciaio.

*Table 4 places, structure in plastic laminated, footrest in steel.*

*Table 4 places, structure en stratifié, repose pieds en acier.*

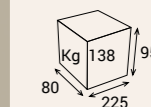
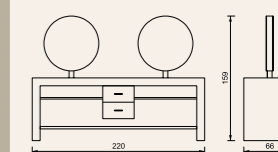



Art. 5182

# POLARIS wall

Modulo 2 posti lavoro,  
struttura in laminato  
plastico, poggiatesta in  
acciaio.

*Styling units 2 working,  
structure in plastic laminated,  
footrest in steel.*

*Coiffeuse à 2 places,  
structure en stratifié, repose  
pieds en acier.*

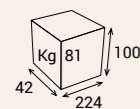
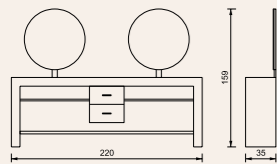

# DESIGN

Art. 4098

Tavolo centrale 4 posti  
lavoro, basamenti in  
cemento fuso, piano  
lavoro in vetro fume',  
arcata in laminato plastico,  
portaphon e prese elettriche  
incorporate.

*Table 4 places, basements in  
cement, top in glass, arch in  
plastic laminate, phonholder  
and current sockets included.*

*Table 4 places, bases de  
beton, top en verre fume', arc  
en stratifié, porte sechoirs et  
prises*

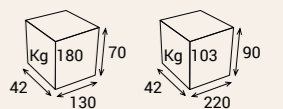
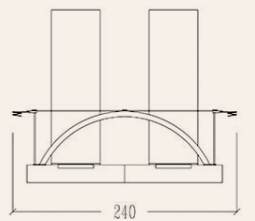
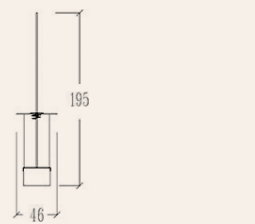

Art. 9324

# NATURAL double

Base in cemento fuso,  
portaphons incorporati.

Basement in cement, phon  
holders included.

Base en beton, porte sechoirs  
incorpores.

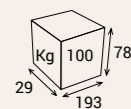
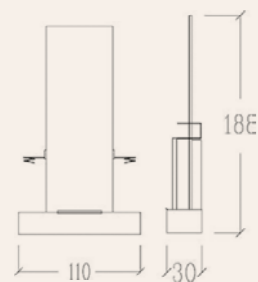
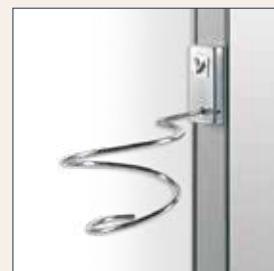

# NATURAL +

Art. 9326

Mobiletto laterale in  
laminato plastico, base in  
cemento.

Lateral structure in laminated,  
base in cement.

Structure laterale en stratifié,  
base en beton.

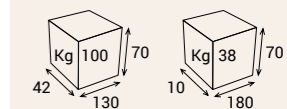
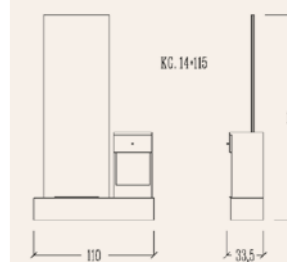

## Art. 9321

# NATURAL light

Struttura in laminato  
plastico, base in cemento  
fuso, lampada decorativa  
incorporata.

*Structure in plastic laminated,  
base en cement, decorative  
lamps included.*

*Structure en stratifié, base  
en beton, lampe decorative  
incorporee.*

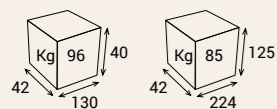
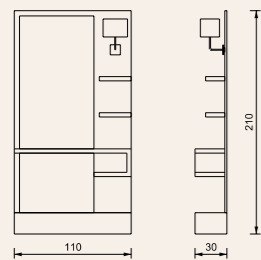

# QUEEN light

## Art. 4009/B

Cornice in agglomerato  
colore argento, piano lavoro  
in vetro fume' poggiatesta  
in acciaio cromato,  
illuminazione decorativa a  
led incorporata.

*Frame in agglomerate with  
decorative led lighting, silver  
color, top in glass, footrest in  
chromium plated metal.*

*Cadre en agglomeré couleur  
argent, tablette en verre  
fume', repose pieds en acier  
chrome', éclairage a' led  
incorporee'.*



## Art. 4009

**Senza illuminazione.  
Without light.  
Sans éclairage.**

Cornice in agglomerato  
colore argento, piano lavoro  
in vetro fume' poggiatesta  
in acciaio cromato.

*Frame in agglomerate, silver  
color, top in glass, footrest in  
chromium plated metal.*

*Cadre en agglomeré couleur  
argent, tablette en verre  
fume', repose pieds en acier  
chrome'.*

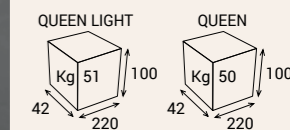
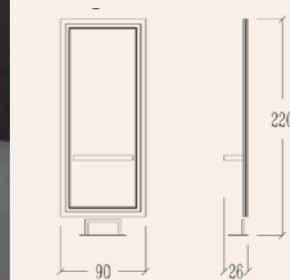



Art. 8242/16

# FLAVIA

VEZZOSIEMPORIO

Struttura in nobilitato nei colori indicati, piano di lavoro in alluminio con foro porta phon, poggiatesta non incluso.

Frame in pre-laminated in the indicated colours top in aluminium with arrangement for dryer holder, foot rest not included.

Structure en laminé dans les couleurs indiqués, plan de travail en aluminium avec trou porte sechoir, repose pieds pas inclus.



BIANCO NERO

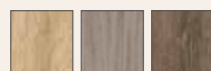

BARDOLINO ROVERE TARTUFO

Nobilitato per struttura. Pre-laminated for frame. Laminé pour structure.

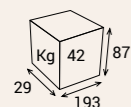
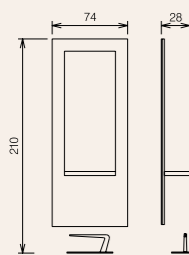

# PASSION GLASS light

Art. 4007

Specchio con contorni acidati, illuminazione incorporata, piano lavoro in vetro trasparente, poggiatesta in metallo cromato.

Mirror with etched outlines, lighting incorporated, top in transparent glass, footrest in chromium plated metal.

Miroir avec contours acides, éclairage incorporé, tablette en verre transparent. Repose pieds en metal chrome.

# PASSION GLASS

Art. 4008

Senza illuminazione. Without light. Sans éclairage.

Specchio con contorni acidati, senza illuminazione, piano lavoro in vetro trasparente, poggiatesta in metallo cromato.

Mirror with etched outlines, without lighting, top in transparent glass, footrest in chromium plated metal.

Miroir avec contours acides, sans éclairage, tablette en verre transparent. Repose pieds en metal chrome.

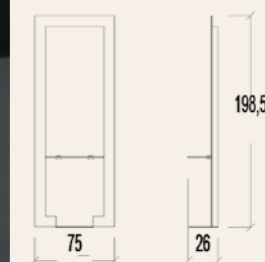

PASSION GLASS LIGHT



PASSION GLASS



Art. 4037

# WHITE STONE

Specchiera con riquadratura in gres di ceramica porcellanato, piano lavoro e supporto poggiatesta in laminato, poggiatesta inclusi, illuminazione decorativa a led incorporata.

*Mirror with frame in porcelain gres with decorative led lighting, top and support of footrest in plastic laminated, footrest included.*

*Structure en carrelage gres, top et support repose pieds en stratifié, repose pieds inclus, éclairage a led incorpore.*

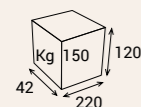
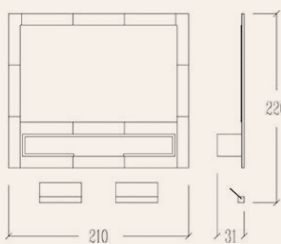

# BLACK STONE

Art. 4035

Struttura con riquadratura in gres di ceramica, piano lavoro alluminio lucido, poggiatesta in acciaio cromato, illuminazione decorativa a led incorporata.

*Mirror with frame in porcelain gres with decorative led lighting, top in aluminium, footrest in chromium plated metal.*

*Structure en carrelage gres, top en aluminium brillant, repose pieds en acier chrome, éclairage a led incorpore.*

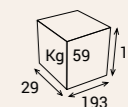
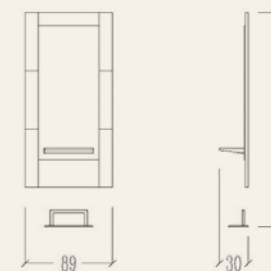



Art. 4021

# SOPHIA one

Struttura e piedi in legno laccato, cornice specchiera in legno agglomerato colore alluminio.

*Frame and feet in laquered wood, cornice in agglomerate wood silver color.*

*Structure et pieds en bois laque', cadre en bois agglomeré' couleur alluminim.*

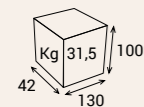
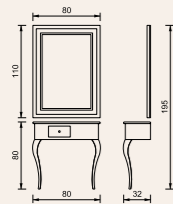

# SOPHIA

Art. 4023

Struttura e piedi in legno laccato, cornice specchiera in legno agglomerato colore alluminio.

*Frame and feet in laquered wood, cornice in agglomerate wood silver color.*

*Structure et pieds en bois laque', cadre en bois agglomeré' couleur alluminim.*

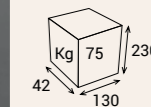
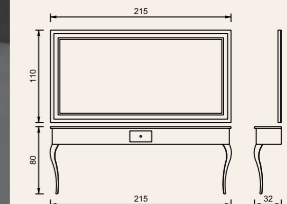



Art. 4022

# SOPHIA wall

Struttura e piedi in legno laccato, cornice specchiera in legno agglomerato colore alluminio.

*Frame and feet in laquered wood, cornice in agglomerate wood silver color.*

*Structure et pieds en bois laque', cadre en bois agglomeré' couleur alluminim.*

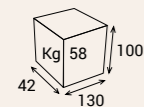
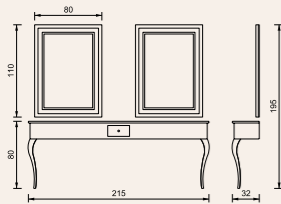

# MARILYN island

Art. 4030

Struttura e piedi in legno laccato, cornice specchiera in legno dorato o a richiesta laccato.

*Frame and feet in laquered wood, cornice in gold wood or by request laquered.*

*Structure et pieds en bois laque', cadre en bois doré' ou sous demande laque'.*

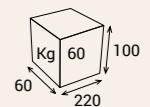
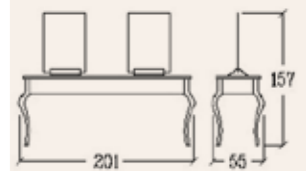



# MAKE UP

Art. 4038

Struttura in laminato, faretto serie egoluce incorporati.

*Coffer in laminated, lighting included.*

*Caisson en lamine, spots serie egoluce incorpores.*

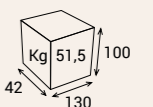
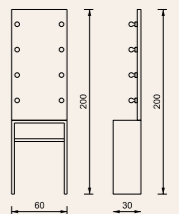







Art. 9327

# EPOQUE wall

VEZZOSIEMPORIO

Specchiera in vetro fuso, finitura in vetro extrachiaro trasparente, specchio centrale a filo lucido illuminazione a led incorporata, piano lavoro in laminato, poggiatesta inclusi.

*Looking glass in melted glass, finish in transparent extralight glass central mirror lighting by led incorporated, top in plastic laminated, foot-rests included.*

*Glace en verre fondu finissage en verre transparent extralight, miroir central, éclairage décorative à led incorporé, top en stratifié, repose pieds inclus.*

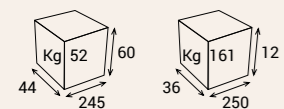
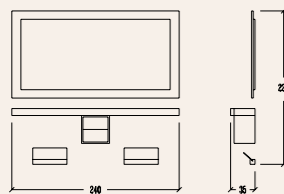

# EPOQUE wall+

VEZZOSIEMPORIO

Art. 9327/P

Specchiera in vetro fuso, finitura in vetro extrachiaro trasparente, specchio centrale a filo lucido illuminazione a led incorporata, piano lavoro in laminato, pannello salvamuro, poggiatesta inclusi.

*Looking glass in melted glass, finish in transparent extralight glass central mirror lighting by led incorporated, top in plastic laminated, panel under top and foot-rests included.*

*Glace en verre fondu finissage en verre transparent extralight, miroir central, éclairage décorative à led incorporé, top en stratifié, panneau sous tablette et repose pieds inclus.*

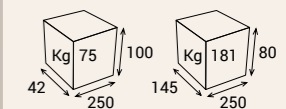
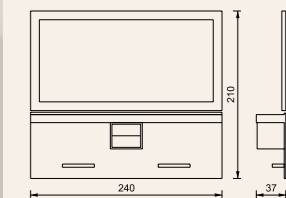

Art. 9330

# EPOQUE 1

VEZZOSIEMPORIO

Specchiera in vetro fuso, finitura in vetro extrachiaro trasparente, specchio centrale a filo lucido illuminazione a led incorporata, piano lavoro in laminato, poggiatesta incluso.

*Looking glass in melted glass, finish in transparent extralight glass central mirror lighting by led incorporated, top in plastic laminated, foot-rests included.*

*Glace en verre fondu finissage en verre transparent extralight, miroir central, éclairage decorative à led incorporé, top en stratifié, repose pieds pas inclus.*

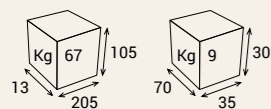
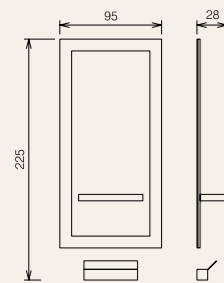

# BAROQUE

Art. 9325

Cornice in legno agglomerato colore alluminio, piano lavoro in legno laccato e vetro retroilluminato da led, poggiatesta laccato e acciaio.

*Frame in agglomerate wood with decorative led lighting, silver color, top in laquered wood and glass with led lighting, footrest in cement and steel.*

*Cadre en bois agglomeré couleur aluminium, top en bois laqué et verre retro éclairé à led. repose pieds laqué et en acier.*

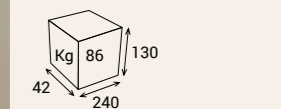
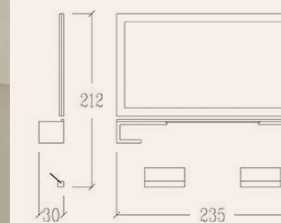
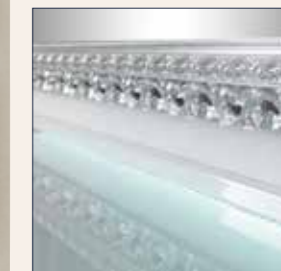

Art. 4155

# XILEMA double

Tavolo centrale 2 posti lavoro, struttura in laminato plastico, angoli e poggiatesta in acciaio.

*Table 2 places, frame in plastic laminated, angles and foot-rest in steel.*

*Table 2 places, structure en stratifié, angulaires et repose-pieds en acier.*

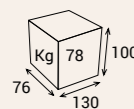
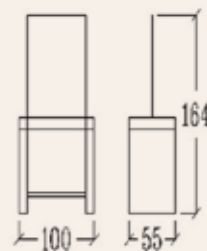

# XILEMA wall

Art. 4150

Struttura in laminato plastico, angoli e poggiatesta in acciaio.

*Frame in plastic laminated, angles and foot-rest in steel.*

*Structure en stratifié, angulaires et repose-pieds en acier.*

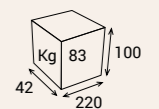
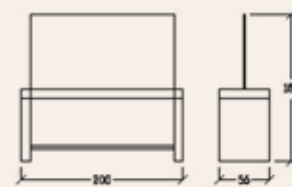



## Art. 4160

# XILEMA island

Tavolo lavoro 4 posti,  
struttura in laminato  
plastico, angoli e  
poggiapiede in acciaio.

*Table 4 places, frame in  
plastic laminated, angles  
and foot-rest in steel.*

*Table 4 places, structure en  
stratifié, angulaires et repose-  
pieds en acier.*

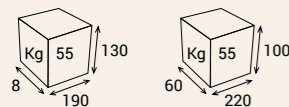
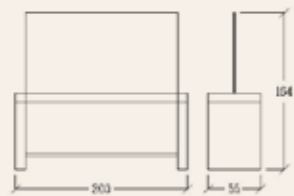

# KOMODO

## Art. 4165

Tavolo lavoro 4 posti,  
struttura in laminato  
plastico, poggiapiedi in  
acciaio.

*Table 4 places, structure in  
plastic laminated, footrest  
in steel.*

*Table 4 places, structure en  
stratifié, repose pieds en  
acier.*

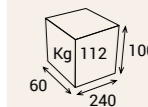
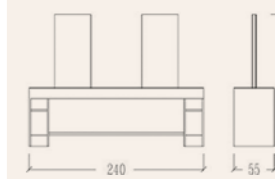



# MOVIE

Art. 8241/16

VEZZOSIEMPORIO

Struttura in nobilitato nei colori indicati, piano lavoro in laminato bianco o nero, poggiapiedi non incluso.

*Frame in pre-laminated in the colours indicated, top in white or black laminated, foot rest not included.*

*Structure en melaminé dans les couleurs indiquées, tablette en stratifié blanc ou noir, repose pieds pas inclus.*



BIANCO NERO



BARDOLINO ROVERE TARTUFO

Nobilitato per struttura.  
Pre-laminated for frame.  
Laminé pour structure.



BIANCO NERO  
LUCIDO LUCIDO

Colori per piano lavoro.  
Colors for shelf.  
Couleurs pour tablette.

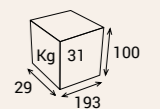
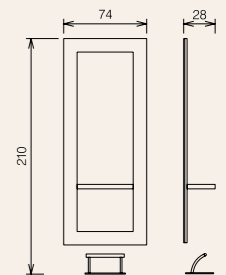





# SUPERNOVA

Art. 8269

VEZZOSIEMPORIO

Modulo 2 posti lavoro, struttura in nobilitato nei colori indicati, piano lavoro in laminato bianco o nero, poggiatesta in tubolare.

*Styling unit 2 places, frame in pre-laminated in the colours indicated, top in white or black laminated, foot rest in steel.*

*Coiffesue à 2 places, structure en melaminé dans les couleurs indiquées, tablette en melaminé blanc ou noir, repose pieds en metal.*



BIANCO NERO

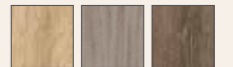

BARDOLINO ROVERE TARTUFO

Nobilitato per struttura.  
Pre-laminated for frame.  
Laminé pour structure.



BIANCO NERO  
LUCIDO LUCIDO

Colori per piano lavoro.  
Colors for shelf.  
Couleurs pour tablette.

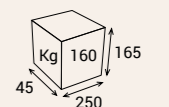
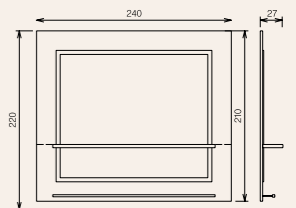



Art. 8268

# LIBERTY

VEZZOSIEMPORIO

Modulo 2 posti lavoro, struttura in nobilitato nei colori indicati, poggiapiedi in acciaio, lampada inclusa.

*Styling unit 2 places, frame in pre-laminated in the colours indicated, foot rest in steel, decorative lamp included.*

*Coiffeuse à 2 places, structure en melaminé dans les couleurs indiquées, repose pieds en métal, lampe décorative incorporée.*



BIANCO NERO

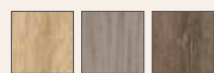

BARDOLINO ROVERE TARTUFO

Nobilitato per struttura. Pre-laminated for frame. Laminé pour structure.

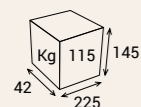
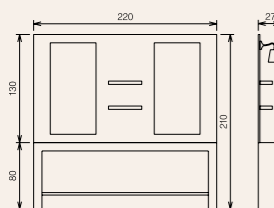

# ROYAL wall

Art. 8266

VEZZOSIEMPORIO

Struttura completamente ricoperta in skai, colore a scelta da nostro campionario, piano lavoro in laminato bianco o nero, poggiapiedi non incluso.

*Frame covered in skai at choice, top in white or black laminated, foot rest not included.*

*Structure recouverte en skai à choix, tablette en stratifié blanc ou noir, repose pieds pas inclus.*



BIANCO NERO  
LUCIDO LUCIDO

Colori per mensola. Colors for shelf. Couleurs pour tablette.

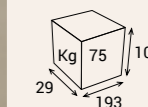
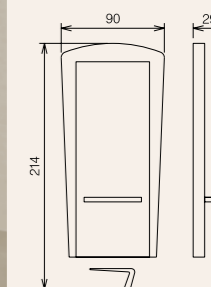

Art. 8271

# ROYAL double

VEZZOSIEMPORIO

Modulo per 2 posti lavoro, fianchi completamente ricoperti in skai, colore tappezzeria a scelta, piano lavoro in laminato bianco, specchi inclusi, poggiatesta satinato.

*Styling unit 2 places, sides in skai at choice, top in white laminated, foot rest in metal.*

*Coiffesue à 2 places, support recouvert en skai à choix, repose pieds en metal.*

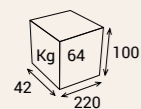
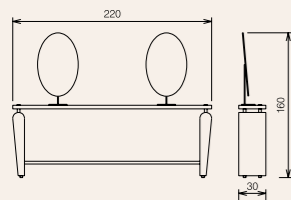
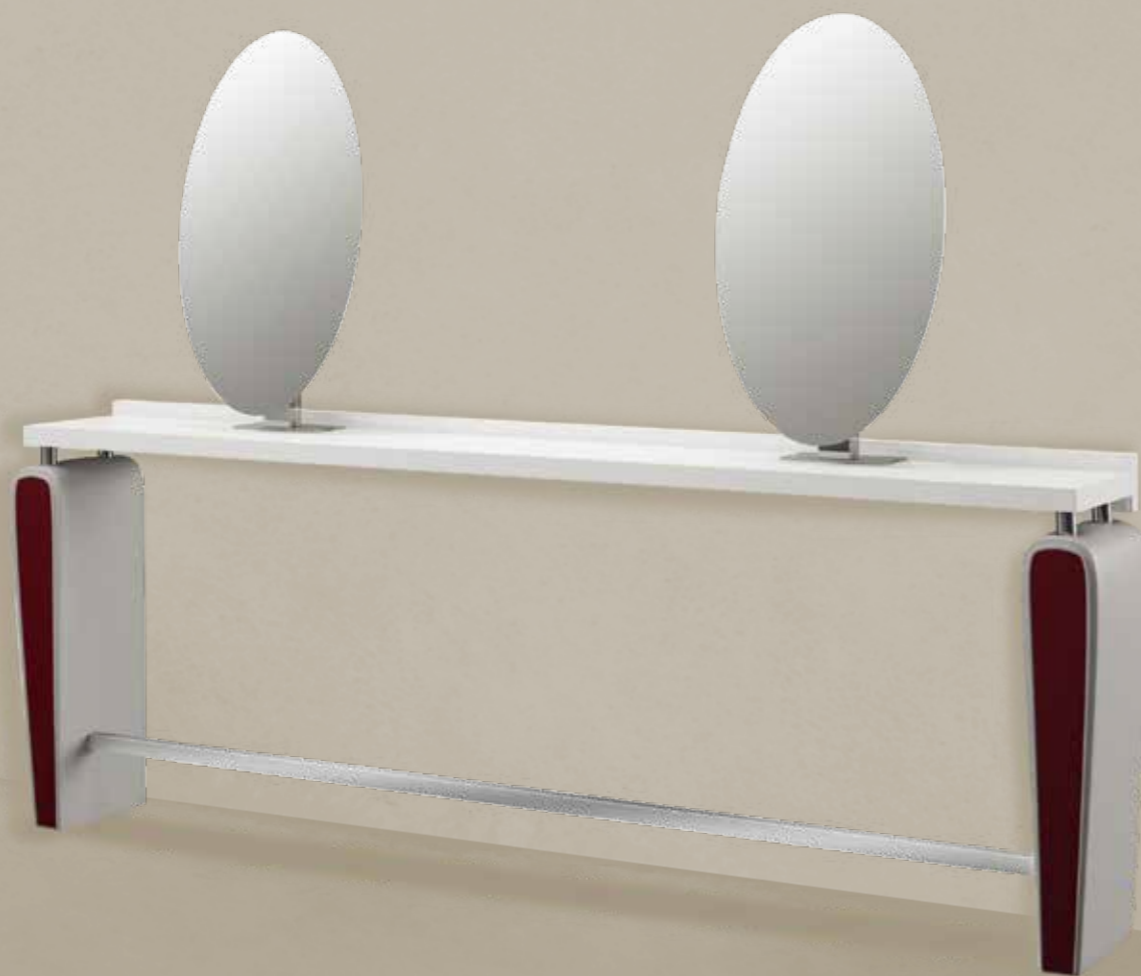

# ROYAL island

Art. 8270

VEZZOSIEMPORIO

Tavolo 4 posti lavoro, fianchi completamente ricoperti in skai, colore tappezzeria a scelta, piano lavoro in laminato bianco, specchi inclusi, poggiatesta satinato.

*Styling table 4 places, sides in skai at choice, top in white laminated, foot rest in metal.*

*Module central 4 places, support recouvert en skai à choix, repose pieds en metal.*

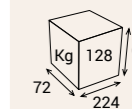
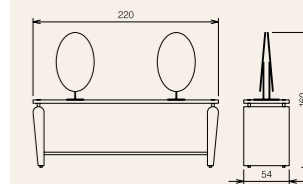





# WATCH

Art. 9328

VEZZOSIEMPORIO

Struttura in laminato  
plastico, cornice alluminio e  
poggiapiede in acciaio inox.

*Structure in plastic laminated,  
frame in aluminium and foot  
rest in stainless steel.*

*Structure en stratifié, cadre  
en aluminium et repose-pied  
en acier inox.*

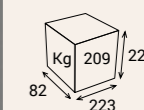
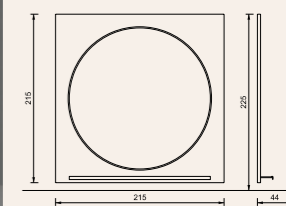



Art. 9228

# WATCH+

VEZZOSIEMPORIO

Struttura in laminato  
plastico con mobiletti  
attrezzati incorporati,  
cornice alluminio e  
poggiapiede in acciaio inox.

*Structure in plastic  
laminated with equipped  
table incorporated, frame in  
aluminium and foot rest in  
stainless steel.*

*Structure en stratifié avec  
incorpore' tables equipées,  
cadre en aluminium et  
repose-pied en acier inox.*

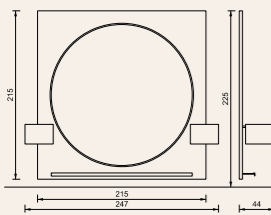

# IKON

Art. 8245

VEZZOSIEMPORIO

Tavolo lavoro 4 posti,  
gambe in vetro temprato.  
Poggiapiedi in acciaio.

*Table 4 places, top in  
plastic laminated, legs in  
tempered glass. Footrest in  
steel.*

*Table 4 places, plan de travail  
en stratifié, jambes en verre  
temperé. Repose pieds en  
acier.*

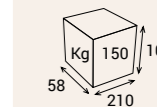
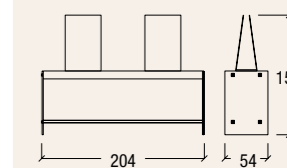



# STRIPE light

Art. 8218/16

VEZZOSIEMPORIO

Decorazione laterale retroilluminata, piano lavoro in laminato bianco o nero, poggiatesta non incluso.

*Lateral decoration with light, top in white or black laminated, foot rest not included.*

*Decorazione laterale retro éclairée, tablette en stratifié blanc ou noir, repose pieds pas inclus.*

# STRIPE

Art. 8217/16

**Senza illuminazione.  
Without light.  
Sans éclairage.**

Decorazione laterale, piano lavoro in laminato bianco o nero, poggiatesta non incluso.

*Lateral decoration, top in white or black laminated, foot rest not included.*

*Decorazione laterale, tablette en stratifié blanc ou noir, repose pieds pas inclus.*



Colori per mensola.  
Colors for shelf.  
Couleurs pour tablette.

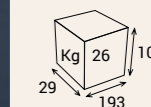
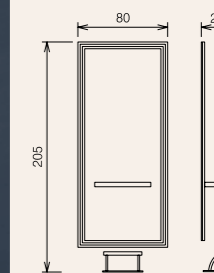



Art. 8234/16

# ONE light

VEZZOSIEMPORIO

Modulo a un posto lavoro con illuminazione a led sui 4 lati. Piano lavoro in nobilitato bianco o nero, poggiatesta non incluso.

*Single styling unit with led light in the 4 sides, top in white or black pre-laminated, foot-rest not included.*

*Coiffeuse individuelle avec éclairage à led dans les 4 côtés, tablette en melaminé blanc ou noir, repose pieds pas inclus.*

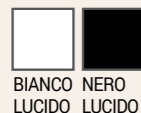

Colori per piano lavoro.  
Colors for shelf.  
Couleurs pour tablette.

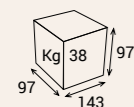
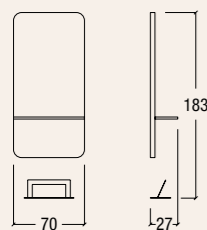

# DOS light

Art. 8236/16

VEZZOSIEMPORIO

Modulo a 2 posti con illuminazione a led sui 4 lati. Piano lavoro in nobilitato bianco o nero, poggiatesta non incluso.

*Double styling unit with led light in the 4 sides, top in white or black pre-laminated, foot-rest not included.*

*Place de travail deux places avec éclairage à led dans les 4 côtés, tablette en melaminé blanc ou noir, repose pieds pas inclus.*

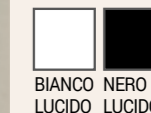

Colori per piano lavoro.  
Colors for shelf.  
Couleurs pour tablette.

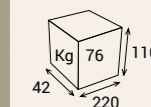
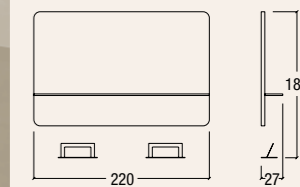



Art. 9342

# OPERÀ

Specchiera in vetro fuso serigrafato bianco, specchio centrale a filo lucido, piano lavoro in postformato bianco, poggiatesta in acciaio.

*Looking glass in melted glass finish in white color, top in white plastic laminated with rounded edge, foot rest in steel.*

*Glace en verre fondu finissage en couleur blanc, tablette en stratifié blanc avec bord arrondi, repose pieds en acier.*



OPERÀ  
service  
Art. 4232

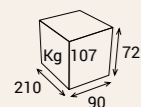
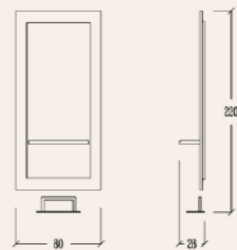

# OPERÀ wall

Art. 9343

Struttura in alluminio, piano lavoro in postformato bianco, poggiatesta in acciaio, specchiera in vetro fuso serigrafato bianco, specchio centrale a filo lucido.

*Structure in aluminium looking glass in melted glass finish in white color, top in white plastic laminated with rounded edge, foot rest in steel.*

*Structure en aluminium glace en verre fondu finissage en couleur blanc, tablette en stratifié blanc avec bord arrondi, repose pieds en acier.*

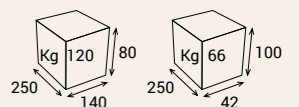
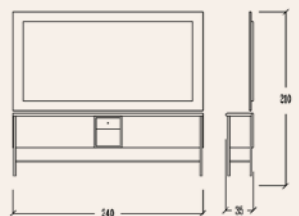



# RING

Art. 9335

Specchio con decoro ad anelli acidati, poggiatesta in acciaio incorporato.

*Mirror with decoration by etched rings, foot rest in steel.*

*Miroir avec decoration par des bagues acide's, repose pieds en acier.*

# SWING

Art. 4231

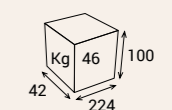
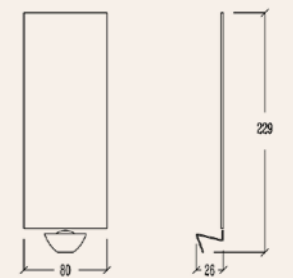



Art. 9336

# NETWORK

Specchio con incisione tridimensionale, poggiatesta in acciaio.

*Mirror with tridimensional engraving, foot rest in steel.*

*Miroir avec gravure tridimensionnelle, repose pieds en acier.*



ROCK  
Art. 4230

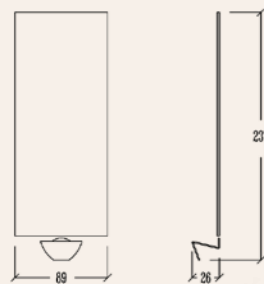

# WAVE

Art. 9337

Specchiera in vetro fuso serigrafato argento, specchio centrale a filo lucido, piano lavoro in laminato plastico, poggiatesta in acciaio.

*Looking glass in melted glass finish in colour silver, central mirror, top in plastic laminated, foot rest in steel.*

*Glace en verre fondu finissage en couleur argent, tablette en stratifié, repose pieds en acier*

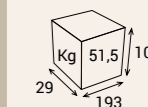
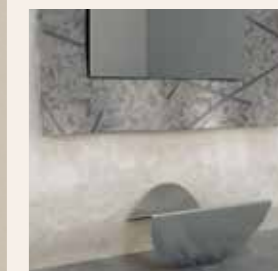

## Art. 5170/B

# MESH light

Struttura in gelcoat colore bianco, piano lavoro laminato, poggiatesta in cemento fuso e acciaio. Illuminazione incorporata.

*Structure gelcoat color white top in plastic laminated, foot-rest in cement and steel. Lighting included.*

*Structure en gelcoat couleur blanc, tablette en stratifié, repose-pieds en béton et acier. Eclairage incorporé.*

## MESH

### Art. 5170

Senza illuminazione.  
*Without light.*  
*Sans éclairage.*

Struttura in gelcoat colore bianco, piano lavoro laminato, poggiatesta in cemento fuso e acciaio.

*Structure gelcoat color white top in plastic laminated, foot-rest in cement and steel.*

*Structure en gelcoat couleur blanc, tablette en stratifié, repose-pieds en béton et acier.*

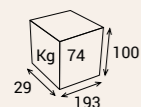
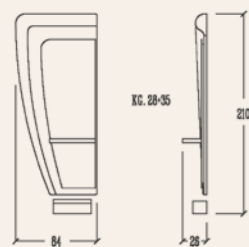

# JUMPER

## Art. 5165

Struttura e piano lavoro in gelcoat colore bianco, poggiatesta in gelcoat e acciaio.

*Structure and shelf gelcoat color white, foot-rest in gelcoat and steel.*

*Structure et tablette en gelcoat couleur blanc, repose-pieds en gelcoat et acier.*

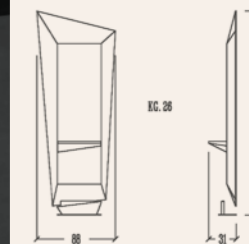





# KRYPTO light

Art. 5160

Struttura in gelcoat colore bianco, piano lavoro laminato, poggiatesta in cemento fuso e acciaio. Illuminazione incorporata.

*Structure gelcoat color white top in plastic laminated, foot-rest in cement and steel. Lighting included.*

*Structure en gelcoat couleur blanc, tablette en stratifié, repose-pieds en béton et acier. Eclairage incorporé.*

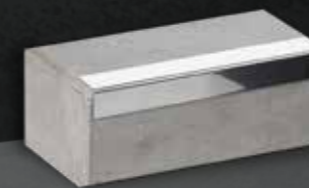

# KRYPTO

Art. 5155

Senza illuminazione.  
Without light.  
Sans éclairage.

Struttura in gelcoat colore bianco, piano lavoro laminato, poggiatesta in cemento fuso e acciaio.

*Structure gelcoat color white top in plastic laminated, foot-rest in cement and steel.*

*Structure en gelcoat couleur blanc, tablette en stratifié, repose-pieds en béton et acier.*

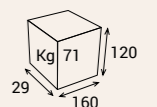
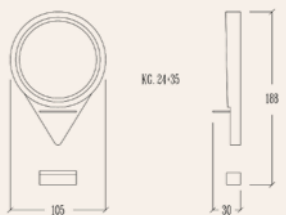

Art. 8233

# CLASH 1

VEZZOSIEMPORIO

Modulo per un posto lavoro,  
struttura in nobilitato nei  
colori indicati.

*Module for one styling units,  
frame in pre-laminated in the  
colours indicated.*

*Module pour un place de  
travail. Structure en laminé  
dans les couleurs indiquées.*



BIANCO NERO



BARDOLINO ROVERE TARTUFO

Nobilitato per piano lavoro.  
*Pre-laminated for shelf.*  
*Laminé pour tablette.*

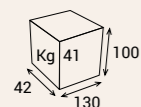
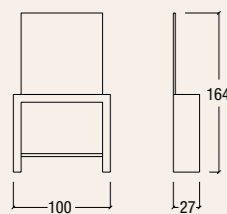

# CLASH

Art. 8230

VEZZOSIEMPORIO

Modulo per due posti lavoro,  
struttura in nobilitato nei  
colori indicati.

*Module for two styling units,  
frame in pre-laminated in the  
colours indicated.*

*Module pour deux places de  
travail. Structure en laminé  
dans les couleurs indiquées.*

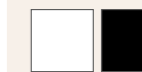

BIANCO NERO



BARDOLINO ROVERE TARTUFO

Nobilitato per piano lavoro.  
*Pre-laminated for shelf.*  
*Laminé pour tablette.*

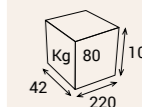
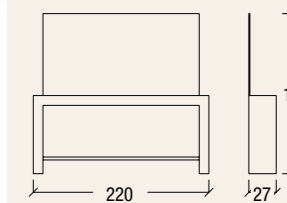



Art. 9845

# CURVE postazione barbiere

Struttura laminato plastico colore a scelta, laterali in materiale poliuretano bianco, lavello e gruppo idraulico compresi.

Frame in plastic laminated color at choice, sides in white polyurethane material, hydraulic pipes included.

structure en startife'couleur a' choice, glace, cotes en materiel poliurethane blanc, robinetterie incorpore'.

**CURVE**  
by Santachiara

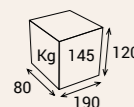
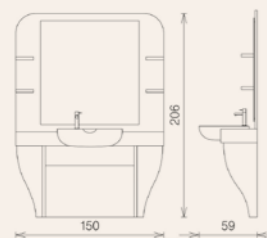

# CURVE postazione barbiere

Art. 9840

Struttura laminato plastico colore a scelta, supporto decorativo in materiale poliuretano bianco, specchio, lavello e gruppo idraulico compresi.

Frame in plastic laminated color at choice, decorative support in white polyurethane material, looking glass, hydraulic pipes included.

Structure en startife'couleur a' choice, glace, support decorative en materiel poliurethane blanc, robinetterie incorpore'.

**CURVE**  
by Santachiara

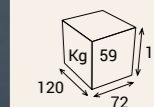
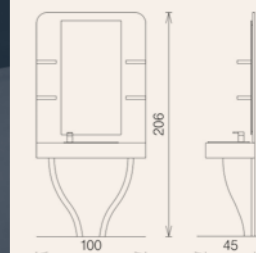

**Art. 4191L  
4191R**

Struttura in laminato  
plastico.

Frame in plastic laminated.

Structure en stratifié.

# JAZZ

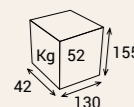
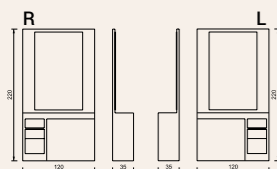

**METEOR +  
Art. 4190P**

Struttura in laminato  
plastico, lavello in ceramica,  
rubinetteria incorporata.

Frame in plastic laminated,  
pottery basin, tap  
incorporated.

Structure en stratifié, basin  
en ceramique, robinetterie  
incorporee.

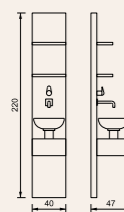

**JAZZ**  
Art. 4191R

**METEOR**  
Art. 4190

**JAZZ**  
Art. 4191L

# GOYA

**Art. 8272**

VEZZOSIEMPORIO



Banco barbiere postazione  
singola, struttura in  
laminato, lavello, gruppo  
idraulico e lampade  
decorative incorporati.

Single Barber Unit frame  
in plastic laminated,  
basin, hydraulic pipes and  
decorative lamps included.

Place de travail barbier  
individuel, structure en  
stratifié, evier, robinetterie  
et lampes decoratives  
incorporées.

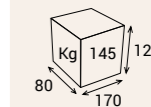
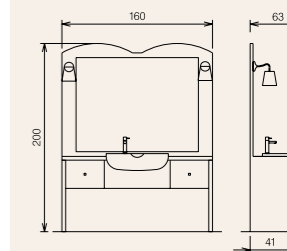



Art. 5190

# GALILEO

Struttura in laminato  
plastico, illuminazione  
incorporata.

Frame in plastic laminated,  
lighting included.

Structure en stratifié,  
éclairage incorporé.

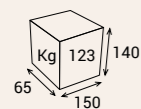

# FIGARO

Art. 5050

Banco a due postazioni,  
struttura in laminato all  
color bianco, lavello gruppo  
idraulico ed illuminazione  
decorativa incorporati.

Unit with 2 places, structure  
in plastic laminated all color  
white, basin, hydraulic pipes  
and decorative lighting  
included.

Place de travail 2 places,  
structure en stratifié all color  
blanc, evier et éclairage  
incorpore.

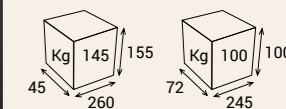
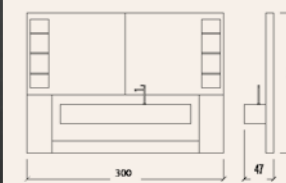

# RETRO 2.0

VEZZOSI EMPORIO





Art. 5052

# RETRO 2.0

VEZZOSIEMPORIO



Banco a 2 postazioni lavoro, struttura in laminato plastico con finiture in legno naturale, lavello gruppo idraulico e lampade decorative incorporati.

*Unit with 2 working places, structure in plastic laminated with decoration in natural wood. Basin, hydraulic pipes and decorative lamps included.*

*Duoble places de travail individuel, structure en stratifié, decoratios en bois naturel evier robinetterie et lampes decoratives incorporees.*

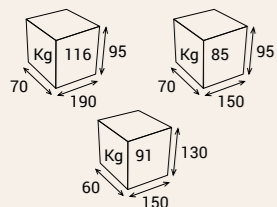
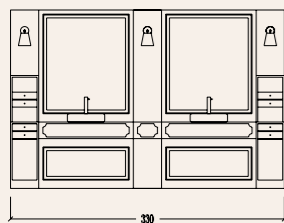
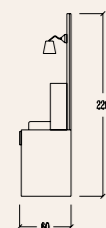

# RETRO

Art. 5051

VEZZOSIEMPORIO



Banco a postazione singola, struttura in laminato plastico con finiture in legno naturale, lavello gruppo idraulico e lampade decorative incorporati.

*Single barber unit, structure in plastic laminated with decoration in natural wood. basin, hydraulic pipes and decorative lamps included.*

*Place de travail individuel, structure en stratifié, decoratios en bois naturel evier robinetterie et lampes decoratives incorporees.*

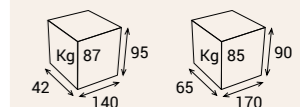
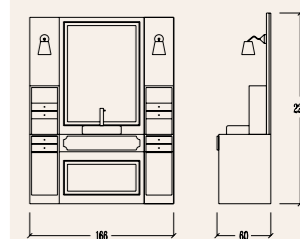



05.

TAVOLI CASSA  
cash register table  
tables caisse







# NEW AGE desk

Art. 6810

Struttura in laminato plastico.

*Structure in plastic laminated.*

*Structure en stratifié.*

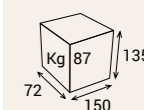
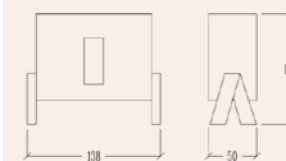

Art. 9815

# CURVE by Santochia cassa

## CURVE

Top in laminato plastico bianco lucido, laterali in materiale poliuretano bianco, frontale a listelli con illuminazione incorporata.

*Top in shine white plastic laminated, sides in white polyurethane material, front in wood listels with lighting incorporated.*

*Top en stratifié blanc brillant cotes en matériel polyuréthane blanc, frontal en lamelles de bois avec éclairage incorporé.*

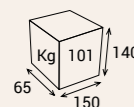
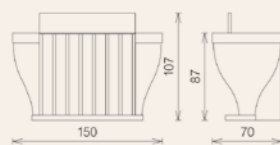

# LOVE

Art. 6755

Struttura in laminato colorpact campionario ABET, illuminazione a led incorporata.

*Structure in laminated colorpact ABET sample, led lighting included.*

*Structure en stratifié colorpact sample ABET, led illumination incorporée.*

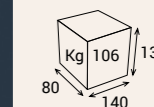
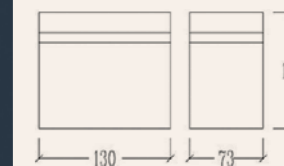





# A.LIGHT

Art. 9950

APP

by Santachiara

Struttura esterna in laminato bianco all color, struttura interna in prelaminato bianco, piano in plexiglass, con illuminazione.

*Outer frame in plastic laminated all color white, inner frame in white pre-laminated, shelf in plexiglass, with lighting.*

*Structure extérieure en stratifié all color blanc, structure intérieure en lamine blanc, tablette en plexiglass, avec illumination.*

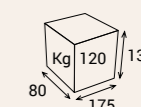
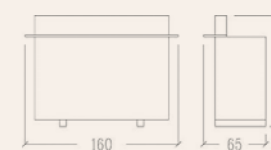
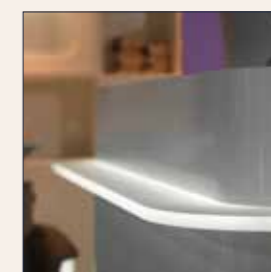

Art. 9550

# POD reception

Struttura verniciata bianca porosa, base in metallo cromato, pianetto a ribaltella con illuminazione incorporata.



*Frame white painted rough, base in chromium plated metal, lighting inside the upsetting shelf.*

*Structure verni blanc rugueux, base en metal chrome, tablette abattante avec eclaireage incorporee.*

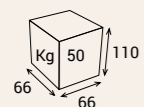
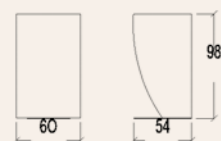

05. | 210

# POD reception

Art. 9500

Struttura verniciata bianca porosa, base in metallo cromato, pianetti a ribaltella con illuminazione incorporata.



*Frame white painted rough, base in chromium plated metal, lighting inside the upsetting shelves.*

*Structure verni blanc rugueux, base en metal chrome, tablettes abattantes avec eclaireage incorporee.*

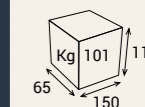

05. | 211



Art. 6300

# COLOUR desk

Specchi basculanti, struttura in laminato plastico, illuminazione incorporata.

*Tilting mirrors, frame in plastic laminated, led lighting included.*

*Miroirs basculantes, structure en stratifié, led illumination incorporée.*

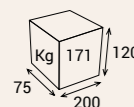
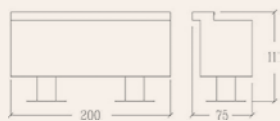

# MOON reception

Art. 6000

Struttura esterna in legno laccato, struttura interna in prelaminato bianco frontale in skai, illuminazione incorporata.

*Outer frame in laquered wood, inner frame in white pre-laminated, frontal in skai with lighting.*

*Structure extérieure en bois laque, structure intérieure en lamine blanc, frontal en skai avec illumination.*

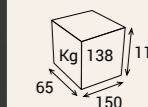
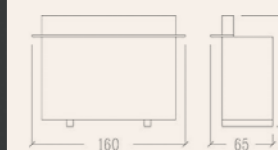

Art. 6758

# LUZ

Struttura in laminato  
plastico, frontale con  
illuminazione ricoperto in  
skai.

*Structure in plastic laminated,  
frontal covered in skai with  
lighting.*

*Structure en stratifié,  
frontal recouvert en skai avec  
éclairage.*

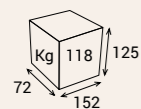
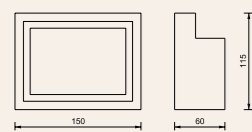

# XILEMA desk

Art. 6800

Struttura in laminato  
plastico con illuminazione  
incorporata.

*Frame in plastic laminated  
with lighting incorporated.*

*Structure en stratifié' avec  
illumination incorporee.*

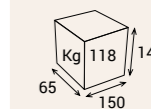
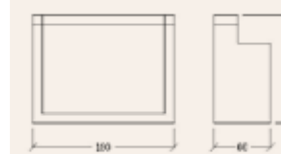



Art. 6756

# CORNER desk

Struttura in laminato  
plastico con illuminazione  
incorporata.

Frame in plastic laminated  
with lighting incorporated.

Structure en stratifié' avec  
illumination incorporee.

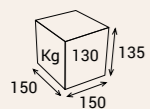
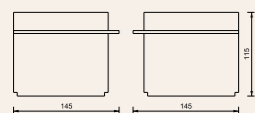

# PEPITA

Art. 6757

Struttura in laminato  
plastico.

Frame in plastic laminated.

Structure en stratifié'.

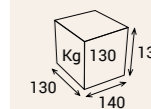
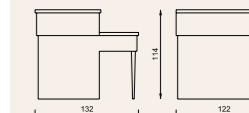

Art. 6190

# NATURAL desk

Struttura in laminato  
plastico, illuminazione a led  
incorporata.

Structure in plastic laminated,  
led lighting included.

Structure en stratifié,  
illumination incorporée.

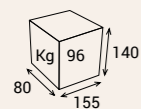
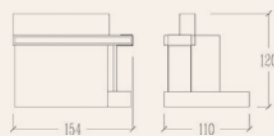

# MARILYN desk

Art. 6030

Struttura e piedi in legno  
laccato.

Frame and feet in laquered  
wood.

Structure et pieds en bois  
laque'.

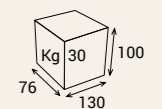





# AUDREY

Art. 8417

VEZZOSIEMPORIO

Struttura in nobilitato nei colori indicati.

Frame in pre-laminated in the indicated colors.

Structure en laminé dans les couleurs indiquées.



BIANCO NERO



BARDOLINO ROVERE TARTUFO

Nobilitato per frontale.  
Pre-laminated for frontal.  
Laminé pour frontal.

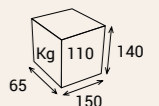
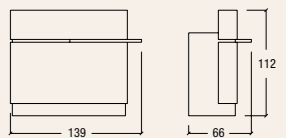

Art. 8426

# AMELIE

VEZZOSIEMPORIO

Struttura e consolle in nobilitato nei colori indicati, illuminazione incorporata.

Frame in pre-laminated in the indicated colours, lighting incorporated.

Structure en melaminé dans les couleurs indiquées, illumination incorporée.



BIANCO NERO



BARDOLINO ROVERE TARTUFO

Nobilitato per frontale.  
Pre-laminated for frontal.  
Laminé pour frontal.



# DORIAN

Art. 8425

VEZZOSIEMPORIO

Struttura in nobilitato nei colori indicati, illuminazione incorporata.

Frame in pre-laminated in the indicated colours, lighting incorporated.

Structure en melaminé dans les couleurs indiquées, illumination incorporée.



BIANCO NERO

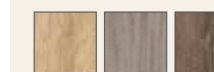

BARDOLINO ROVERE TARTUFO

Nobilitato per frontale.  
Pre-laminated for frontal.  
Laminé pour frontal.

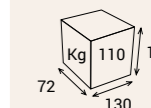
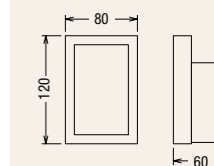
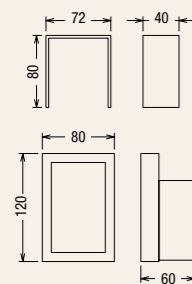





Art. 8424

# ROYAL desk

VEZZOSIEMPORIO

Struttura in nobilitato nei colori indicati, frontale imbottito e completamente ricoperto in skai, colore tappezzeria a scelta.

Frame in pre-laminated in the indicated colours, frontal covered in skai at choice.

Structure en melaminé dans les couleurs indiquées, frontal recouvert en skai à choix.

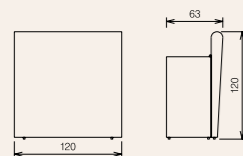

Art. 8416

# SMILE

VEZZOSIEMPORIO

Struttura e frontale in nobilitato nei colori indicati, illuminazione frontale con striscia di led.

Frame and frontal in pre laminated in the indicated colours, frontal lighting with strip of led.

Structure et frontal en melamine dans les couleurs indiquées, éclairage frontale avec bande de led.



BIANCO NERO



BARDOLINO ROVERE TARTUFO

Nobilitato per frontale. Pre-laminated for frontal. Laminé pour frontal.3

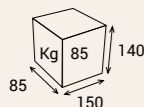
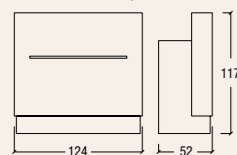

# LUMINOL

VEZZOSIEMPORIO

Art. 8414

Struttura in nobilitato nei colori indicati. Illuminazione incorporata.

Frame in pre-laminated in the indicated colours. Lighting incorporated.

Structure en laminé dans les couleurs indiquées, illumination incorporée.



BIANCO NERO

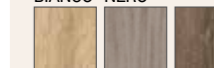

BARDOLINO ROVERE TARTUFO

Nobilitato per frontale. Pre-laminated for frontal. Laminé pour frontal.

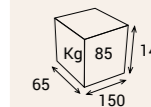
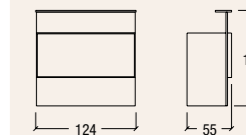

# J-LO desk

VEZZOSIEMPORIO

Art. 8415

Struttura in nobilitato nei colori indicati, frontale in skai con finitura capitonné.

Frame in pre-laminated in the indicated colours, frontal in skai capitonné.

Structure en laminé dans les couleurs indiquées, frontal en skai capitonné.



BIANCO NERO

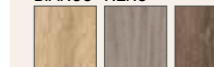

BARDOLINO ROVERE TARTUFO

Nobilitato per frontale. Pre-laminated for frontal. Laminé pour frontal.

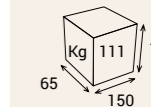
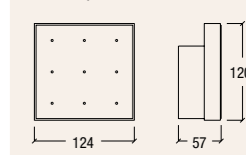





# SPICE

Art. 8410

VEZZOSIEMPORIO



BARDOLINO ROVERE TARTUFO BIANCO NERO

Nobilitato per struttura.  
Pre-laminated for frame.  
Laminé pour structure.



Struttura in nobilitato nei colori indicati. Illuminazione incorporata.

Frame in pre-laminated in the indicated colors. Lighting incorporated.

Structure en laminé dans les couleurs indiquées, illumination incorporée.

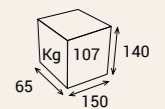
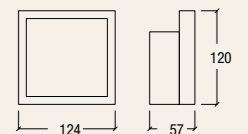

# WELCOME

Art. 8428

VEZZOSIEMPORIO



BARDOLINO ROVERE TARTUFO BIANCO NERO

Nobilitato per struttura.  
Pre-laminated for frame.  
Laminé pour structure.

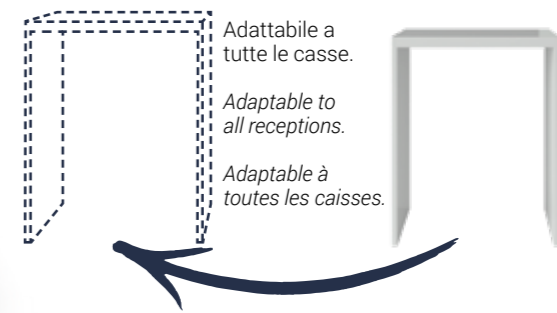
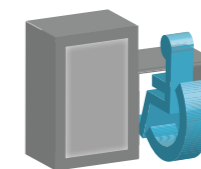

Adattabile a tutte le casse.

Adaptable to all receptions.

Adaptable à toutes les caisses.

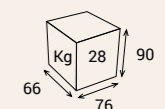
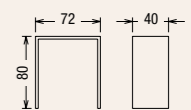
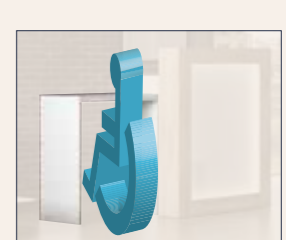



06.

MOBILI EXPO  
expo furnishing  
meubles expo





Art. 9895

# CURVE expo

**CURVE**  
by Santochiara

Struttura e piani in laminato  
plastico bianco lucido,  
fianchi in laminato plastico  
colore a scelta.

*Frame and shelves in shine  
white plastic laminated, sides  
in plastic laminated colour at  
choice.*

*Structure et tablettes en  
stratifié blanc brillant, lateral  
en stratifié couleur à choix.*

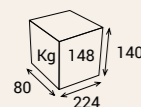
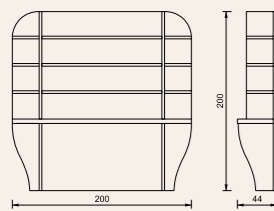

# JUMPER expo

Art. 565

Struttura in gelcoat bianco,  
piani in vetro.

*Frame in gelcoat white, tops  
in glass.*

*Structure en gelcoat blanc,  
tablettes en verre.*

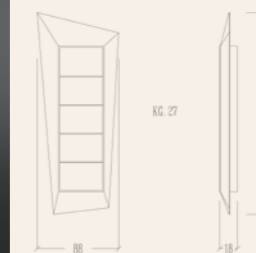





## Art. 506

# NATURAL expo

Struttura e piani in laminato plastico con illuminazione incorporata, base in cemento.

*Structure and shelves in plastic laminated with light inside, base in cement.*

*Structure et tablettes en stratifié avec illumination incorporée, base en béton.*

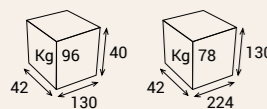
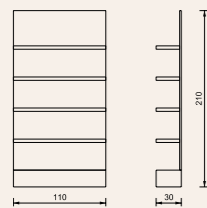

# XILEMA expo

## Art. 510

Struttura in laminato plastico, piani in vetro, angoli acciaio.

*Frame in plastic laminated wood, tops in glass, angles in steel.*

*Structure en stratifié, tablettes en verre, angulaires en acier.*

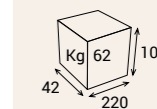

## Art. 504

# SKAI expo maxi

Fondale ricoperto in sky, piani e base in acciaio, piantone tubolare ferro verniciato.

*Background in upholstery, tops in steel, stucture in painted iron.*

*Fond en skai, etageres et base en acier, pie fer verni.*

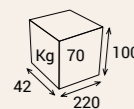
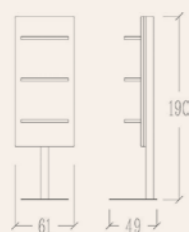

## Art. 505

# SKAI expo

Fondale ricoperto in skai, piani acciaio.

*Background in upholstery, tops in steel.*

*Fond en skai, tablettes en acier.*

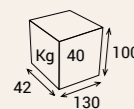
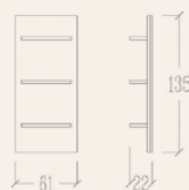

06. | 238

# EXPO new

## Art. 8601/16

VEZZOSIEMPORIO

Struttura in nobilitato nei colori indicati, piani in vetro.

*Frame in pre-laminated in the indicated colours, shelves in glass.*

*Structure en laminé dans les couleurs indiquées, tablettes en verre.*



BIANCO 478  
LUCIDO GREY

Nobilitato per struttura.  
*Pre-laminated for frame.*  
Laminé pour structure.

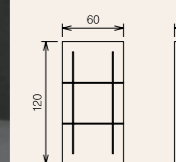

06. | 239



Art. 8604

# DADA expo

VEZZOSIEMPORIO

Struttura in nobilitato bianco, sportelli e expo superiori in primeboard p2 colore super opaco grigio antracite o grigio cashmere.

Frame in pre-laminated white, doors and expo in primeboard p2 super dull colour grey anthracite or grey cashmere.

Structure en laminé blanc, portieres et expo en primeboard p2 super opaque gris anthracite ou gris cashmere.



## OPTIONAL

Sportelli in laminato. Vedi listino.

Doors in plastic laminated. See price list.

Portieres en stratifié. Voir la liste de prix.

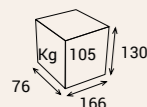
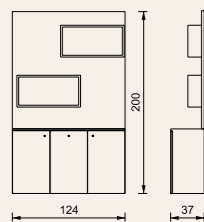

# REALITY expo

Art. 8603

VEZZOSIEMPORIO

Struttura in nobilitato nei colori indicati, piani in vetro.

Frame in pre-laminated in the indicated colours, shelves in glass.

Structure en laminé dans les couleurs indiquées, tablettes en verre.



BIANCO NERO

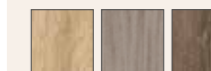

BARDOLINO ROVERE TARTUFO

Nobilitato per struttura. Pre-laminated for frame. Laminé pour structure.

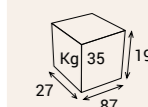
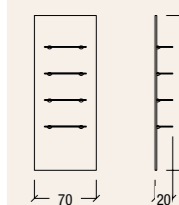



**MOBILI SERVIZIO**  
salon furnishing  
meubles de rangement







# CURVE mobile

Art. 9885

**CURVE**  
by Santachiara

Struttura in laminato bianco lucido, sportelli in laminato plastico colore a scelta, laterali in materiale poliuretano bianco.

*Frame in shine white plastic laminated, doors in laminated colour at choice, sides in white polyurethane material.*

*Structure en stratifié blanc brillant, portieres en stratifié couleur à choix, cotes en matériel poliurethane blanc.*

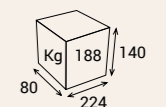
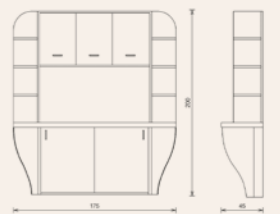

Art. 6305

# COLOUR service

Struttura e sportelli in laminato plastico.

Frame and doors in plastic laminated.

Structure et portieres en stratifié.

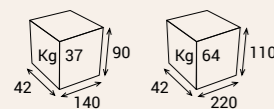
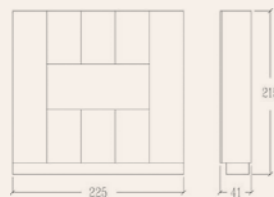

# WOOD

Art. 9360/B

Struttura in nobilitato color bianco con tubolari in acciaio retroilluminati a led, cassetti visual e sportelli in laminato plastico colore a scelta, mensole in vetro.

Frame in pre-laminated colour white with tubulars in steel lighted with led, drawers visual and doors in plastic laminated colour at choice, shelves in glass.

Structure en lamine' couleur blanc avec tubulaires en acier eclaire' a led, tiroirs visual et portieres en stratifié' couleur au choix, tablettes en verre.

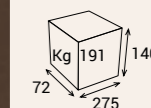

Art. 9360

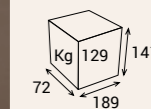





# BEAUTY

Art. 9355

Struttura in laminato  
plastico, lavello inox, gruppo  
idraulico ed illuminazione a  
led incorporata.

*Structure in plastic laminated,  
inox basin, hydraulic pipe and  
lighting included.*

*Structure en stratifié, inox  
basin et éclairage incorpores*

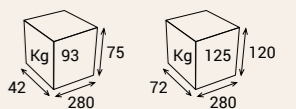
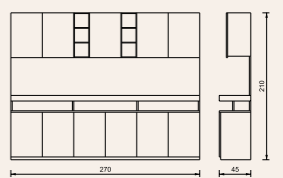





# LUXURY

Art. 9350

Struttura in laminato all color bianco top e salvamuro in gres porcellanato tipo lamina, lavello inox, gruppo idraulico e illuminazione a faretti incorporata.

*Structure in plastic laminated "all color" white, top and wall cover in porcelain gres "3 mm", inox basin, hydraulics pipes, lighting included.*

*Structure en stratifié all color blanc, top et protection en carrelage gres lamina. Evier complet en inox et éclairage incorpores.*

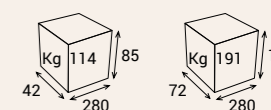
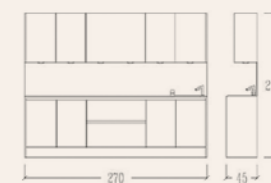



## Art. 707

# MOBILI

Struttura in nobilitato bianco lucido sportelli in primeboard p2 colore super opaco grigio antracite o grigio cashmere piedi in metallo lucidato.

*Frame in prelaminated color white doors in primeboard p2 super dull colour grey anthracite or grey cashmere, feet in shine metal.*

*Structure en lamine' blanc brillant, portieres en primeboard p2 super opaque gris anthracite ou gris cashmere, pieds en metal cire'.*



## OPTIONAL

Sportelli in laminato.  
**Vedi listino.**

*Doors in plastic laminated.  
**See price list.***

*Portieres en stratifié.  
**Voir la liste de prix.***

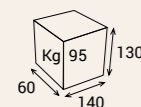
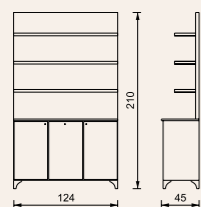

# MOBILI

## Art. 706

Struttura in nobilitato bianco lucido sportelli in primeboard p2 colore super opaco grigio antracite o grigio cashmere piedi in metallo lucidato.

*Frame in prelaminated color white doors in primeboard p2 super dull colour grey anthracite or grey cashmere, feet in shine metal.*

*Structure en lamine' blanc brillant, portieres en primeboard p2 super opaque gris anthracite ou gris cashmere, pieds en metal cire'.*



## OPTIONAL

Sportelli in laminato.  
**Vedi listino.**

*Doors in plastic laminated.  
**See price list.***

*Portieres en stratifié.  
**Voir la liste de prix.***

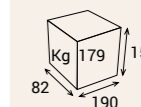
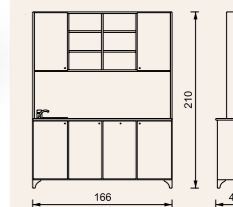

## Art. 705

# MOBILI

Struttura in nobilitato bianco lucido sportelli in primeboard p2 colore super opaco grigio antracite o grigio cashmere piedi in metallo lucidato.

*Frame in prelaminated color white doors in primeboard p2 super dull colour grey anthracite or grey cashmere, feet in shine metal.*

*Structure en lamine' blanc brillant, portieres en primeboard p2 super opaque gris anthracite ou gris cashmere, pieds en metal cire'.*



## OPTIONAL

Sportelli in laminato.  
**Vedi listino.**

*Doors in plastic laminated.  
**See price list.***

*Portieres en stratifié.  
**Voir la liste de prix.***

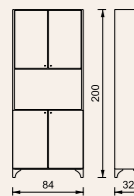

# MOBILI

## Art. 702

Struttura in nobilitato bianco lucido sportelli in primeboard p2 colore super opaco grigio antracite o grigio cashmere piedi in metallo lucidato.

*Frame in prelaminated color white doors in primeboard p2 super dull colour grey anthracite or grey cashmere, feet in shine metal.*

*Structure en lamine' blanc brillant, portieres en primeboard p2 super opaque gris anthracite ou gris cashmere, pieds en metal cire'.*



## OPTIONAL

Sportelli in laminato.  
**Vedi listino.**

*Doors in plastic laminated.  
**See price list.***

*Portieres en stratifié.  
**Voir la liste de prix.***

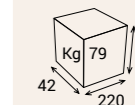
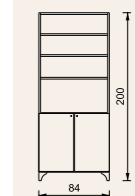



Art. 8730/16

# MOBILI

VEZZOSIEMPORIO

Struttura in nobilitato bianco lucido sportelli in primeboard p2 colore super opaco grigio antracite o grigio cashmere.

Frame in prelaminated color white doors in primeboard p2 super dull colour grey anthracite or grey cashmere.

Structure en lamine' blanc brillant, portieres en primeboard p2 super opaque gris anthracite ou gris cashmere.



## OPTIONAL

Sportelli in laminato. Vedi listino.

Doors in plastic laminated. See price list.

Portieres en stratifié. Voir la liste de prix.

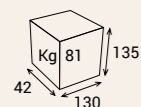
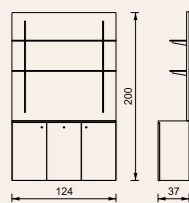

# MOBILI

Art. 8731/16

VEZZOSIEMPORIO

Struttura in nobilitato bianco lucido sportelli in primeboard p2 colore super opaco grigio antracite o grigio cashmere.

Frame in prelaminated color white doors in primeboard p2 super dull colour grey anthracite or grey cashmere.

Structure en lamine' blanc brillant, portieres en primeboard p2 super opaque gris anthracite ou gris cashmere.



## OPTIONAL

Sportelli in laminato. Vedi listino.

Doors in plastic laminated. See price list.

Portieres en stratifié. Voir la liste de prix.

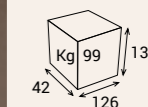
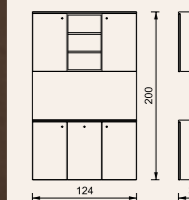

Art. 8726

# MOBILI

VEZZOSIEMPORIO

Struttura in nobilitato bianco lucido sportelli in primeboard p2 colore super opaco grigio antracite o grigio cashmere piedi in metallo lucidato.

Frame in prelaminated color white doors in primeboard p2 super dull colour grey anthracite or grey cashmere, feet in shine metal.

Structure en lamine' blanc brillant, portieres en primeboard p2 super opaque gris anthracite ou gris cashmere, pieds en metal cire'.

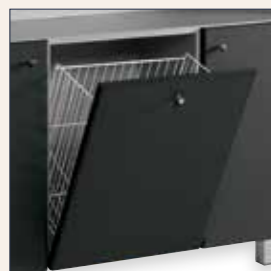

Art. 8700/16

Art. 8725/16

Art. 8700/16

## OPTIONAL

Sportelli in laminato. Vedi listino.

Doors in plastic laminated. See price list.

Portieres en stratifié. Voir la liste de prix.

# MOBILI

VEZZOSIEMPORIO

Art. 8725/16  
8720/16  
8700/16

Struttura in nobilitato bianco lucido sportelli in primeboard p2 colore super opaco grigio antracite o grigio cashmere piedi in metallo lucidato.

Frame in prelaminated color white doors in primeboard p2 super dull colour grey anthracite or grey cashmere, feet in shine metal.

Structure en lamine' blanc brillant, portieres en primeboard p2 super opaque gris anthracite ou gris cashmere, pieds en metal cire'.

Art. 8726

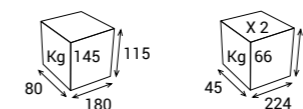
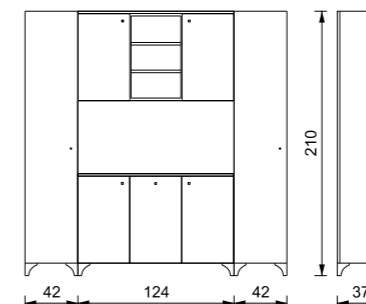

Art. 8725/16

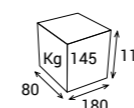
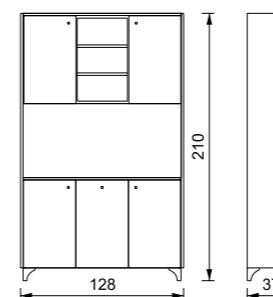

Art. 8700/16

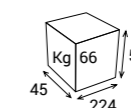
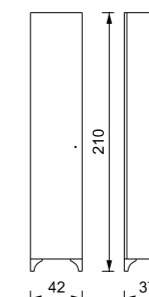

Art. 8720/16

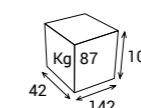
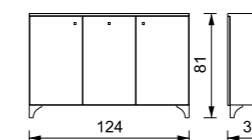

## OPTIONAL

Sportelli in laminato. Vedi listino.

Doors in plastic laminated. See price list.

Portieres en stratifié. Voir la liste de prix.





COMPLEMENTI  
complements  
compléments



Art. 7195

# XILEMA closet

Appendiabiti, struttura in laminato plastico, particolari in acciaio.

Wardrobe, frame in plastic laminated, details in steel.

Vestiaire, structure en stratifié, détails en acier.

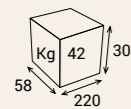
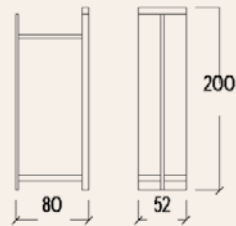

# GRAFFIO

Art. 7190

Appendiabiti, struttura in metallo verniciato con plexiglass inserito.

Wardrobe, frame in painted metal with inside plexiglass.

Vestiaire, structure en metal verni avec dedans plexiglass.

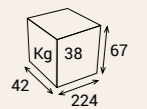
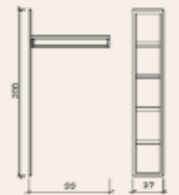



Art. 4225

# SOUL



Struttura in laminato plastico.

Frame in plastic laminated.

Structure en stratifié.

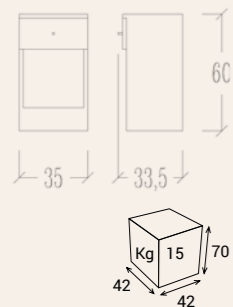

Art. 4220

# TOTEM



Struttura in laminato plastico.

Frame in plastic laminated.

Structure en stratifié.

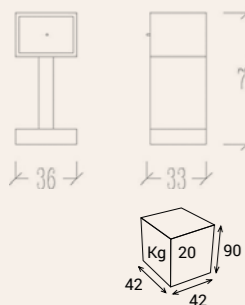

Art. 4201

# YORK



Struttura in laminato plastico.

Frame in plastic laminated.

Structure en stratifié.

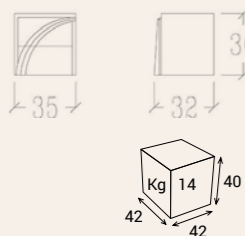

# BRAD

Art. 8251/16

VEZZOSIEMPORIO



BARDOLINO ROVERE TARTUFO BIANCO NERO

Nobilitato per struttura.  
Pre-laminated for frame.  
Laminé pour structure.



Struttura in nobilitato nei colori indicati, piedi in metallo lucidato.

Structure in pre-laminated in the indicated colours, feet in shine metal.

Structure en melaminé dans les couleurs indiquées, pieds en metal ciré.

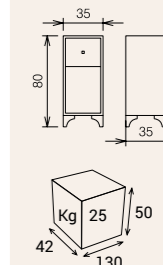

# STYLE

Art. 8250

VEZZOSIEMPORIO



BARDOLINO ROVERE TARTUFO BIANCO NERO

Nobilitato per struttura.  
Pre-laminated for frame.  
Laminé pour structure.



Struttura e frontale in nobilitato nei colori indicati.

Frame and frontal in pre-laminated in the indicated colours.

Structure et frontal en melaminé dans les couleurs indiquées.

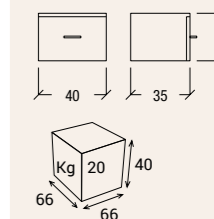

Art. 4231

# SWING

Struttura in laminato  
plastico, piano in vetro.

Frame in plastic laminated,  
shelve in glass.

Structure en stratifié,  
tablette en verre.

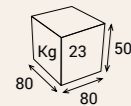
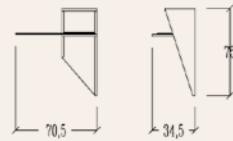

Art. 4230

# ROCK

Struttura in laminato  
plastico e piano in laminato.

Frame and shelve  
in plastic laminated.

Structure et tablette  
en stratifié.

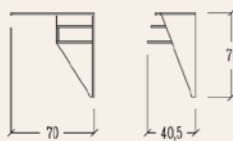

# METEOR +

Art. 4190P

Struttura in laminato  
plastico, lavello in ceramica,  
rubinetteria incorporata.

Frame in plastic laminated,  
pottery basin, tap  
incorporated.

Structure en stratifié', basin  
en ceramique, robinetterie  
incorporee.

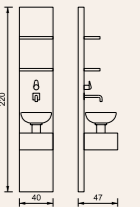

# METEOR basic

Art. 5075

Struttura in laminato  
plastico, lavello in ceramica,  
rubinetteria incorporata.

Frame in plastic laminated,  
pottery basin, tap  
incorporated.

Structure en stratifié', basin  
en ceramique, robinetterie  
incorporee.

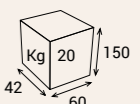
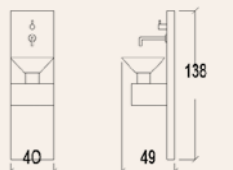



## OPERA service

Art. 4232

Struttura in alluminio,  
mobiletto in laminato  
plastico.

*Frame in aluminium, service  
in plastic laminated.*

*Structure en aluminium,  
coffre en stratifié.*

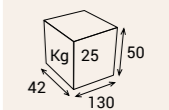
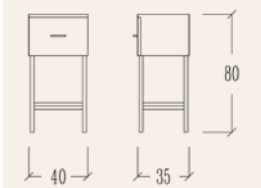

## COOL

Art. 4215

Struttura in laminato plastico.

*Frame in plastic laminated.*

*Structure en stratifié.*

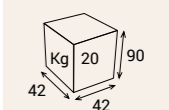
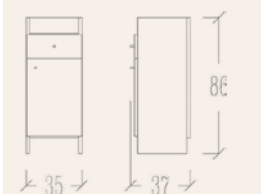



Art. 7271

# YOUNG

Struttura, cassetti, piano superiore e ruote in propilene, piedi in metallo cromato. Cassetti nei colori indicati.

Structure in abs, drawers and wheels in polypropylene, pieds in metal chrome. Drawers in the displayed colors.

Structure en abs, tiroirs and roues en polypropilene, pieds en metal chrome. Tiroirs dans les couleurs presentes

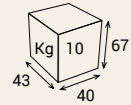
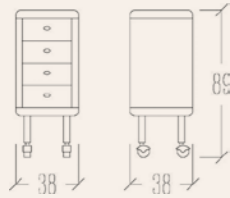

Art. 7272

# OZZY

Carrello con struttura e frontale cassetti chiuso con finiture antigraffio. Mensola laterale portaphon, ciotola in materiale anticacida. Ruote trasparenti anticapello.

Trolley with structure and drawers frontal closed surface anti scratch. Lateral shelf, hairdryer holder, antiacid bowl. Transparent wheels hair proof.

Chariot avec structure et frontal des tiroirs fermés. Surface antirayure. Tablette porte sechoir. Bol antiacide. Roulettes transparents anti cheveu.

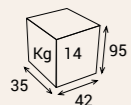
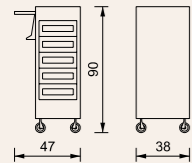

08. 270



# HOLLY

Art. 7277

Carrello porta attrezzi a 5 cassetti, piano superiore con portaphon e tazzina, telaio in legno verniciato grigio.

Trolley with 5 drawers, top shelf with hairdryer holder and cup, frame in painted wood grey.

Table de service avec 5 tiroirs, tablette avec porte sechoir et bol de coloration, structure en bois verni gris.

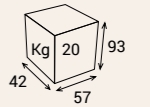
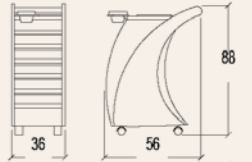

# WOW

Art. 7270

Struttura in abs cassetti, piano superiore, ruote in polipropilene

Structure in abs, drawers, wheels in polypropylene.

Structure en abs, tiroirs, top, roues en polypropylène.

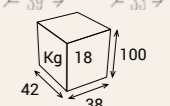
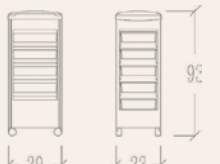

# FLUYDO

Art. 7278

Carrello tinture con porta tazzine e porta rotoli, struttura legno verniciato grigio.

Colouring trolley, complete with cup holder, roll holder, structure in wood colour grey.

Chariot teintures avec bol de coloration, structure en bois gris.

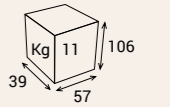
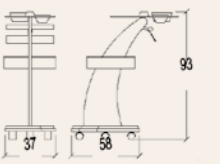

08. 271

Art. 9890

# CURVE portaphon

Portaphon universale in metallo cromato.

Universal dryholder in chromium plated metal.

Porte-sechoir universel en metal chrome'.



**CURVE**  
by Santachiara



Art. 7256

# POR TAPHON

Portaphon in alluminio lucidato.

Dryholder in shiny aluminium.

Porte-sechoir en aluminium.



Art. 7255

# A. POR TAPHON

Portaphon in materiale poliuretano nei colori bianco e nero.

Dryholder in polyurethane material colour white or black.

Porte-sechoir en materiel poliurethane couleur blanc ou noir

**APP**  
by Santachiara



Art. 7250

# VORTICE

Portaphon universale in metallo cromato.

Universal dryholder in chromium plated metal.

Porte-sechoir universel en metal chrome'.



# VALENTINO

Art. 5070

Cono portalavello in metallo verniciato, lavello acciaio, piedi in alluminio lucidato, cassonetto in laminato plastico.

Cone basin-stand in painted metal, inox basin, feet in shine aluminium, case in plastic laminated.

Cone porte-basin en metal verni, basin inox, pieds en aluminium brillant,caisson en stratifié'.

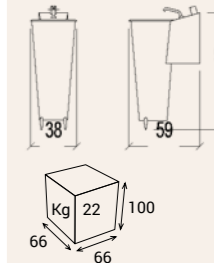

# VOGUE

Art. 7279

Carrello porta riviste, struttura in legno, scomparti in plexiglass.

Trolley for magazine, frame in wood with four transparent plexiglass compartments.

Chariot porte magazine, structure en bois, compartiments en plexiglass.

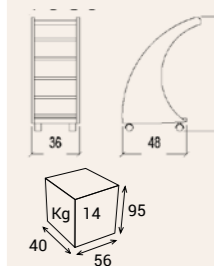

# IRON

Art. 7275

Sterilizzatore in abs, spegnimento automatico all'apertura dello sportello, lampadina a 9 watt.

Sterilizer in abs, it automatically switches off when the flap is opened, lamp 9 watt.

Sterilisateur en abs, extinction automatique lors que le guichet est ouvert, ampoule 9 watt.

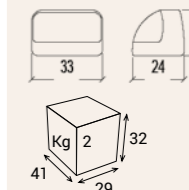

Art. 7290

# FRIEND

Specchio da tavolo, base in alluminio.

*Mirror for table, base in aluminium.*

*Miroir pour table, base en aluminium.*

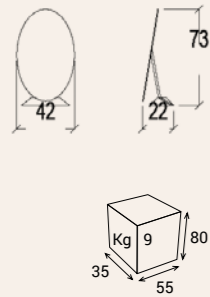

Art. 7291

# HOLLYWOOD

Specchio bifacciale, base in legno dorato o a richiesta laccato.

*Two faces mirror, base in gold wood or by request laquered.*

*Miroir biphaccial, base en bois dore' ou sous demande laque'.*

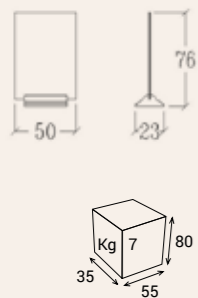

08. | 274

# TENDER double

Art. 7292

Specchio doppio da tavolo, base in alluminio.

*Mirror double for table, base in aluminium.*

*Miroir double pour table, base en aluminium.*

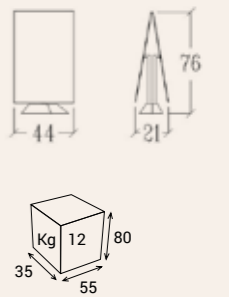

# TENDER

Art. 7293

Specchio da tavolo, base in alluminio.

*Mirror for table, base in aluminium.*

*Miroir pour table, base en aluminium.*

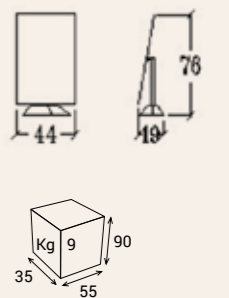

08. | 275



Art. 7145

# ENERGY

Sgabello, base in alluminio lucidato, sedile in sky, schienale in plexiglass bianco.

*Stool, shine aluminum base, seat in sky, back in white plexiglass.*

*Tabouret, base en aluminium brillant, siege en sky, dossier en plexiglass blanc.*

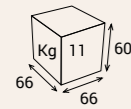
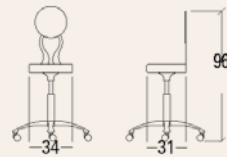

Art. 7143

# BOLERO

Sgabello, base in alluminio lucidato, sedile in sky.

*Stool, shine aluminum base, seat in sky.*

*Tabouret, base en aluminium brillant, siege en sky.*

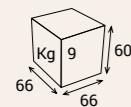
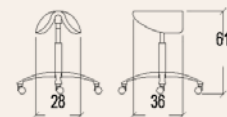

# FELIX

Art. 8253

Sgabello, base in alluminio lucidato, sedile e schienale in skai.

*Stool, shine aluminum base, seat and backrest in skai.*

*Tabouret, base en aluminium brillant, siege et dossier en skai.*

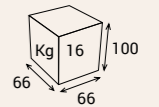
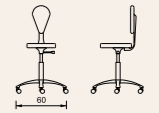

# KID

Art. 8252

VEZZOSIEMPORIO

Sgabello, base in alluminio lucidato, seduta in skai.

*Stool, shine aluminium base, seat in skai.*

*Tabouret, base en aluminium brillant, siege en skai.*

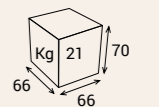
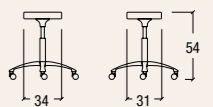



ESTETICA  
beauty items  
esthétique



VEZZOSI

Art. 10025/N

# PITAGORA

Letto elettrico di alta gamma a 2 piani con struttura molto stabile e robusta. Equipaggiato di un motore che permette di regolare l'altezza e di uno schienale regolabile manualmente. Ruote retrattili.

*Aesthetic bed of high range of 2 bodies with very stable and robust structure. Equipped with an engine that allows to adjust the height and manually adjustable backrest. Wheels for easy scrolling included.*

*Table électrique de haute-gamme à 2 plans avec structure très stable et robuste. Équipé d'un moteur qui permet de régler la hauteur et d'un dossier réglable manuellement. Roulettes escamotables incluses.*

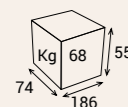
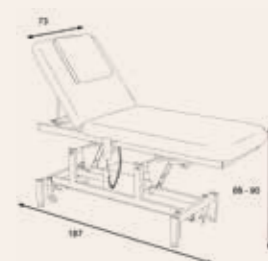

# POPPER

Art. 10015/N

Letto massaggi in legno colore wengé. Regolabile in altezza. Inclinazione dello schienale regolabile manualmente. Foro per viso, cuscino facciale in silicone ergonomico.

*Aesthetics bed in solid wood wenge color. Adjustable in height. The inclination of the backrest is regulated manually. Lower shelf for storage. Includes removable articulated head as well as an ergonomic silicone facial cushion.*

*Lit à 2 corps en bois de wengé massif. Réglable en hauteur. L'inclinaison du dossier se règle manuellement. Étagère inférieure pour rangement. Comprends une tête articulée amovible et un coussin facial en silicone ergonomique.*

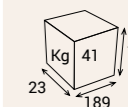





# TIFFANY

Art. 10055/N

Poltrona pedicure SPA con rivestimento colore bianco. Vasca pedicure con idromassaggio a getto d'acqua, doccia, scarico e rubinetteria inclusi. Seduta mobile per ottenere la giusta posizione e facilitare l'accesso.

*SPA pedicure armchair upholstered in high quality PU. Footbath with hydromassage with jet function, shower head with extendable hose, drainage system and mixer taps. The seat slides to adjust the position and facilitate access..*

*Fauteuil de pédicure SPA avec revêtement en PU de haute qualité. Bain de pieds avec hydromassage et jet d'eau, douche, système d'écoulement et robinetterie. L'assise glisse pour ajuster la position et faciliter l'accès.*

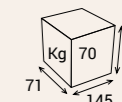

Art. 10035/N

# HARRY

Sgabello con pompetta a gas per la regolazione dell'altezza. Seduta e schienale squadrati colore bianco, con ruote in silicone, eccellente aderenza e lunga durata.

Stool equipped with a gas piston to adjust the height. Square seat with flat backrest white and soft rolling silicone wheels, great grip and long life.

Tabouret équipé d'un vérin à gaz pour régler la hauteur. Assise et dossier carrés couleur blanc avec roulettes en silicone à roulement doux, excellente adhérence et longue durée.

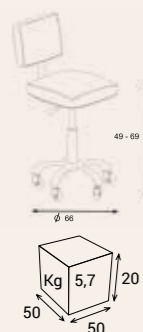

Art. 10091/N

# DANY

Carrello con struttura in metallo, 3 ripiani, 1 cassetto, 4 ruote in silicone con freno, ottima aderenza e lunga durata. Colore bianco.

Trolley with metallic structure, 3 trays with a lower drawer, handle and wheels. The drawers are wooden. Color white.

Chariot avec 3 étagères, 1 tiroir, poignée et 4 roulettes avec frein en silicone, à roulement doux, excellente adhérence et longue durée. Couleur blanc.

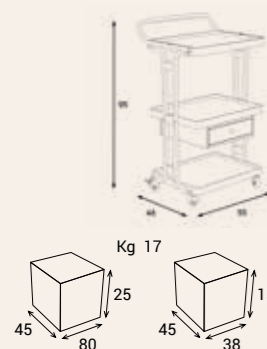

# IGGY

Art. 10090/N

VEZZOSIEMPORIO

Carrello manicure con piano appoggio.

Manicure trolley.

Manicure service.

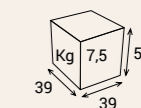
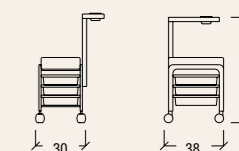

# KIMI

Art. 10060/B

VEZZOSIEMPORIO

Vaporizzatore digitale viso.

Vaporizer digital for face.

Vaporisateur digitale pour visage.

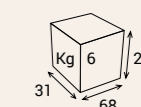
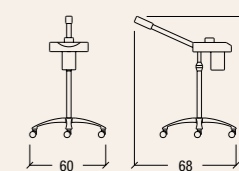

Art. 10105/N

Struttura in legno laccato, aspiratore e poggiamani incorporati.

Structure in laquered wood, nail dust collector and handrest cushion included.

Structure en bois laqué, aspirateur et coussin appui main inclus.

# MARILYN nails



**MARILYN nails**  
Art. 10105/N

**EXPO nails**  
Art. 10106/N

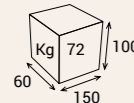

# EXPO nails

Art. 10106/N

Espositore per smalti.

Nail polish expo.

Produits expo.



# GRACE +

Art. 10065/N16

VEZZOSIEMPORIO



BIANCO LUCIDO

Nobilitato per struttura. Pre-laminated for frame. Laminé pour structure.



Tavolo manicure con espositore per smalti. Ripiani in vetro, struttura in nobilitato bianco, cassettiere, aspiratori e poggiamani incorporati.

Manicure table with nails polish expo, shelves in glass, frame in pre-laminated in white colour, nails dust collector and handrest cushion included.

Table manicure avec expositeur des produit, etageres en verre, structure melaminee blanc, aspirateur et coussin appui main inclus.

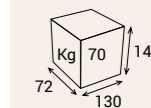
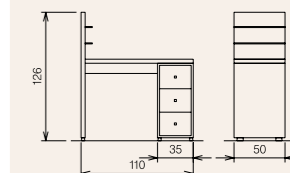

# GRACE double

Art. 10064/N

VEZZOSIEMPORIO



BIANCO LUCIDO

Nobilitato per struttura. Pre-laminated for frame. Laminé pour structure.



Doppio tavolo manicure con espositore per smalti al centro. Ripiani in vetro, struttura in nobilitato bianco, cassettiere, aspiratori e poggiamani incorporati.

Double manicure table with double nails polish expo, shelves in glass, frame in pre-laminated in white colour, nails dust collector and handrest cushion included.

Double table manicure avec double expositeur des produit, etageres en verre, structure melaminee blanc, aspirateur et coussin appui main inclus.

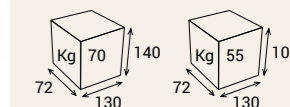
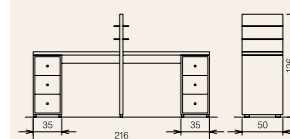



## Art. 10080/N

Tavolo manicure in nobilitato nei 2 colori indicati, accessori inclusi.

*Manicure table in pre-laminated in the 2 indicated colours, accessories included.*

*Table de manicure en laminé dans les 2 couleurs indiquées, accessoires inclus.*

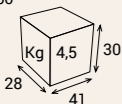
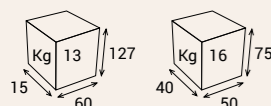
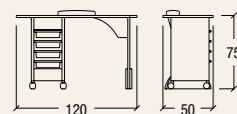

## Art. 10075/N

Tavolo manicure in nobilitato nei 2 colori indicati, accessori inclusi.

*Manicure table in pre-laminated in the 2 indicated colours, accessories included.*

*Table de manicure en laminé dans les 2 couleurs indiquées, accessoires inclus.*

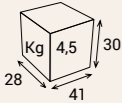
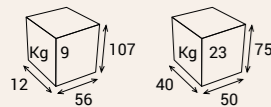
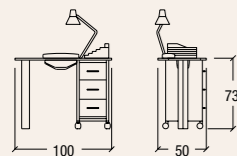

# LOU

VEZZOSIEMPORIO



BIANCO 478  
LUCIDO GREY

Nobilitato per struttura.  
Pre-laminated for frame.  
Laminé pour structure.



# JOEY

VEZZOSIEMPORIO



BIANCO 478  
LUCIDO GREY

Nobilitato per struttura.  
Pre-laminated for frame.  
Laminé pour structure.



# ALICE

## Art. 10085/N

VEZZOSIEMPORIO

Lampada tavolo con lente a 3 diottrie.

*Magnifying lamp 3 diopter.*

*Lampe pour table à 3 odioptries.*



# ALICE con piede

## Art. 10086/N

VEZZOSIEMPORIO

Lampada con piede, lente a 3 diottrie.

*Magnifying lamp with foot, 3 diopter.*

*Lampe avec pied à 3 odioptries.*



# NELLY

## Art. 10095/N

VEZZOSIEMPORIO

Lampada a luce calda da tavolo. Lampadina esclusa. Potenza massima 60 watt.

*Warm light table lamp. Bulb not included. Max power: 60 watt.*

*Lampe chauffante pour table. Sans ampoule. Puissance max: 60 watt.*





POGGIA PIEDI – PIEDI  
foot-rest and feet  
repose-pieds – pieds



# POGGIAPIEDI . foot-rest . repose-pieds

## Art. 7340

Poggiapiede in acciaio e alluminio lavorato.

*Foot-rest in steel and aluminium.*

*Repose-pieds en acier et aluminium.*



## Art. 7335

Poggiapiede in acciaio satinato piegato.

*Foot-rest in steel.*

*Repose-pieds en acier.*



## Art. 7310

Poggiapiede in cemento e acciaio.

*Foot-rest in cement and steel.*

*Repose-pieds en beton et acier.*



## Art. 7315

JUMPER: Poggiapiede in gelcoat e acciaio.

JUMPER: *Foot-rest in gelcoat and steel.*

JUMPER: *Repose-pieds en gelcoat et acier.*



## Art. 9970

Poggiapiedi in acciaio, supporto in materiale poliuretano bianco.

*Foot-rest in steel, support in white polyurethane material.*

*Repose-pieds en acier, support en materiel polyurethane blanc.*



by Santachiara



# POGGIAPIEDI . foot-rest . repose-pieds

## Art. 7300

Poggiapiede in metallo cromato.

*Foot-rest in chromium plated metal.*

*Repose-pieds en metal chrome'.*

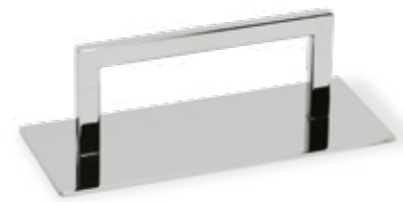

## Art. 7330

Poggiapiede in metallo satinato.

*Foot-rest in chromium glazed metal.*

*Repose-pieds en metal satine'.*



## Art. 7325

Poggiapiede in alluminio lucidato e satinato.

*Foot-rest in shine and glazed aluminium.*

*Repose-pieds en aluminium brillant et satine'.*



## Art. 5600

Poggiapiede in alluminio lucidato e satinato.

*Foot-rest in shine and glazed aluminium.*

*Repose-pieds en aluminium brillant et satine'.*



## Art. 9390

Poggiapiede in cemento e acciaio.

*Foot-rest in cement and steel.*

*Repose-pieds en beton et acier.*





PIEDI . feet . pieds

P 21



P 20



P 70



P 51



P 31

Verniciato.  
Painted.  
Verni.



P 30

Verniciato.  
Painted.  
Verni.



P 40

Verniciato.  
Painted.  
Verni.



P 41

Verniciato.  
Painted.  
Verni.



P 81



P 80



P 98



P 99



P 05



P 15

Verniciato.  
Painted.  
Verni.



P 90



P 95





11.

CASCHI  
hairdryer  
sechoir



## Art. 1160

# GOKU

Casco asciugacapelli in materiale plastico, interno in nylon, a regolazione digitale completamente elettronica, asciugatura a ventilazione diretta, colori di serie: nero o grigio argento metallizzato.

*Hairdryer in plastic material, inner in nylon, digital regulation totally electronic, direct ventilation drying, standard colour: metal black or silver.*

*Sechoir en materiel plastique, interieur en nylon, reglage digitale completement eletronique, sechage a ventilation directe, couleurs de serie: noir ou gris metallise'.*



Art. 1160

# VICTOR

## Art. 1610

Vaporizzatore con temporizzatore e regolazione dell'intensita' del vapore, costruito in nylon, caldaia in acciaio inox, colori di serie: nero o grigio argento metallizzato.

*Hairstreamer with timer and steam setting, built in nylon, inox kettle, standard colour: metal black or silver.*

*Casque a vapeur avec temporisateur et reglage de l'intensite' du vapeur, construit en nylon, chaudiere en acier inox, couleurs de serie: noir ou gris metallise'.*



Art. 1610

Art. 1170



Art. 1150



Art. 1620

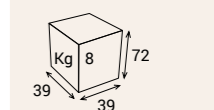
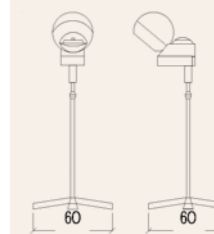
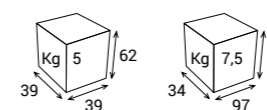
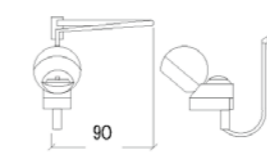
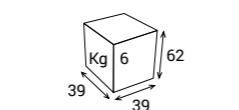
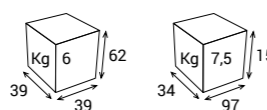
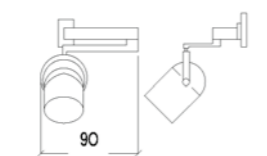
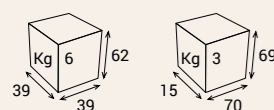
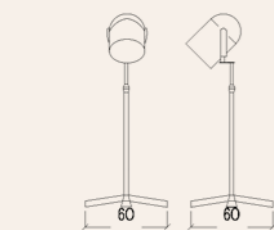



## Art. 1110

# GINKO

Casco asciugacapelli in abs, con doppio isolamento, interno in nylon, doppia campana fume', con asciugatura a pressione d'aria, regolazione elettronica della velocità, colori di serie: nero o grigio argento metallizzato.

*Hairdryer in abs plastic material, with double insulation, inner in nylon, double hood fume', with air pressure drying, electronic regulation of speed, standard colour: metal black or silver.*

*Sechoir en abs materiel plastique, avec double isolation, interieur en nylon, double coiffe fumee, avec sechage a'pression d'air, reglage eletronique de la vitesse, couleurs de serie: noir ou gris metallise'.*



Art. 1110

# DARWIN

## Art. 1010

Casco asciugacapelli con ventilazione diretta, a 2 velocità, costruito in abs, con doppio isolamento, interno in nylon, timer 60', termoregolatore di energia per il calore con resistenza filare, colori di serie: nero o grigio argento metallizzato.

*Hairdryer with direct ventilation, 2 speed, built in abs plastic material, with double insulation, inner in nylon, timer 60', ttermoregulator of power for the heat with cables resistance, standard colour: metal black or silver.*

*Sechoir a' ventilation directe, au 2 vitesse, en abs materiel plastique, avec double isolation, interieur en nylon, minuterie 60', thermoregulateur de temperature avec resistance a' filaments, couleurs de serie: noir ou gris metallise'.*



Art. 1010

Art. 1120



Art. 1100



Art. 1020



Art. 1000

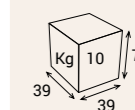
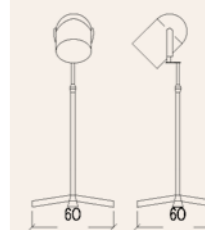
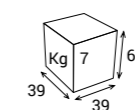
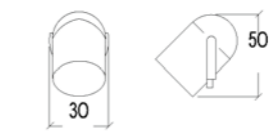
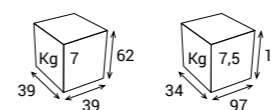
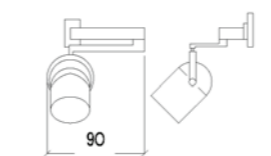
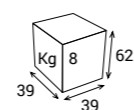
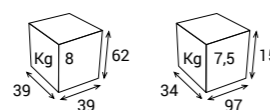
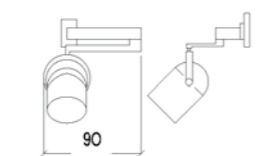
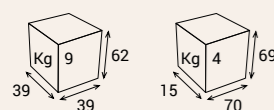
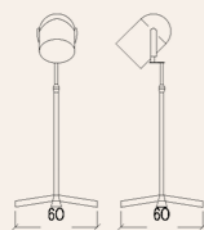

## Art. 1210

# RADIUS

Casco asciugacapelli in abs, con doppio isolamento, interno in nylon, termostato bimetallo, timer 60', colori di serie: bianco.

*Hairdryer in abs plastic material, with double insulation, inner in nylon, double metal thermostat, timer 60', standard colour: white.*

*Sechoir en abs materiel plastique, avec double isolation, interieur en nylon, thermostat bimetalique, minuterie 60', couleurs de serie: blanc.*



Art. 1210



Art. 1810

## Art. 1810

Lampada ventilata, interno acciaio, esterno termoformato grigio, resistenze circolari al quarzo regolabili singolarmente, temporizzatore 60', potenza 1400 watts 230 volts 50-60 hz, colori di serie: grigio chiaro.

*Airy lamp, inside frame in steel, outside in polyurethane grey, circular quartz resistances adjusting separately, timer 60', power 1400 watts 230 volts 50-60 hz, standard colour light grey.*

*Lampe aere', structure interieure en acier, exterieure en poliurethane gris, resistances circulaires au quartz reglables separement, timer 60', puissance 1400 watts 230 volts 50-60 hz, couleurs de serie: gris claire.*

Art. 1220



Art. 1200



Art. 1820



Art. 1800

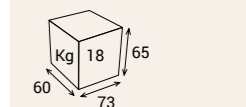
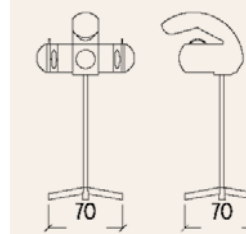
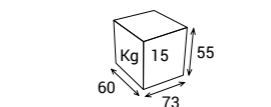
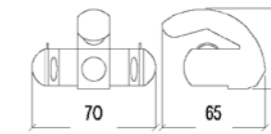
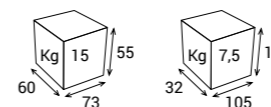
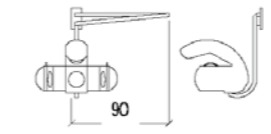
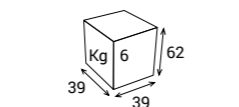
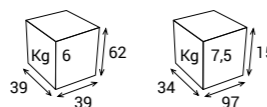
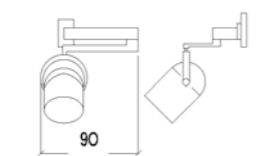
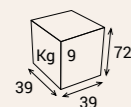
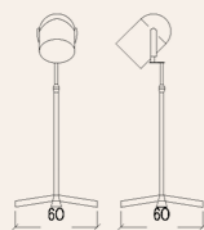

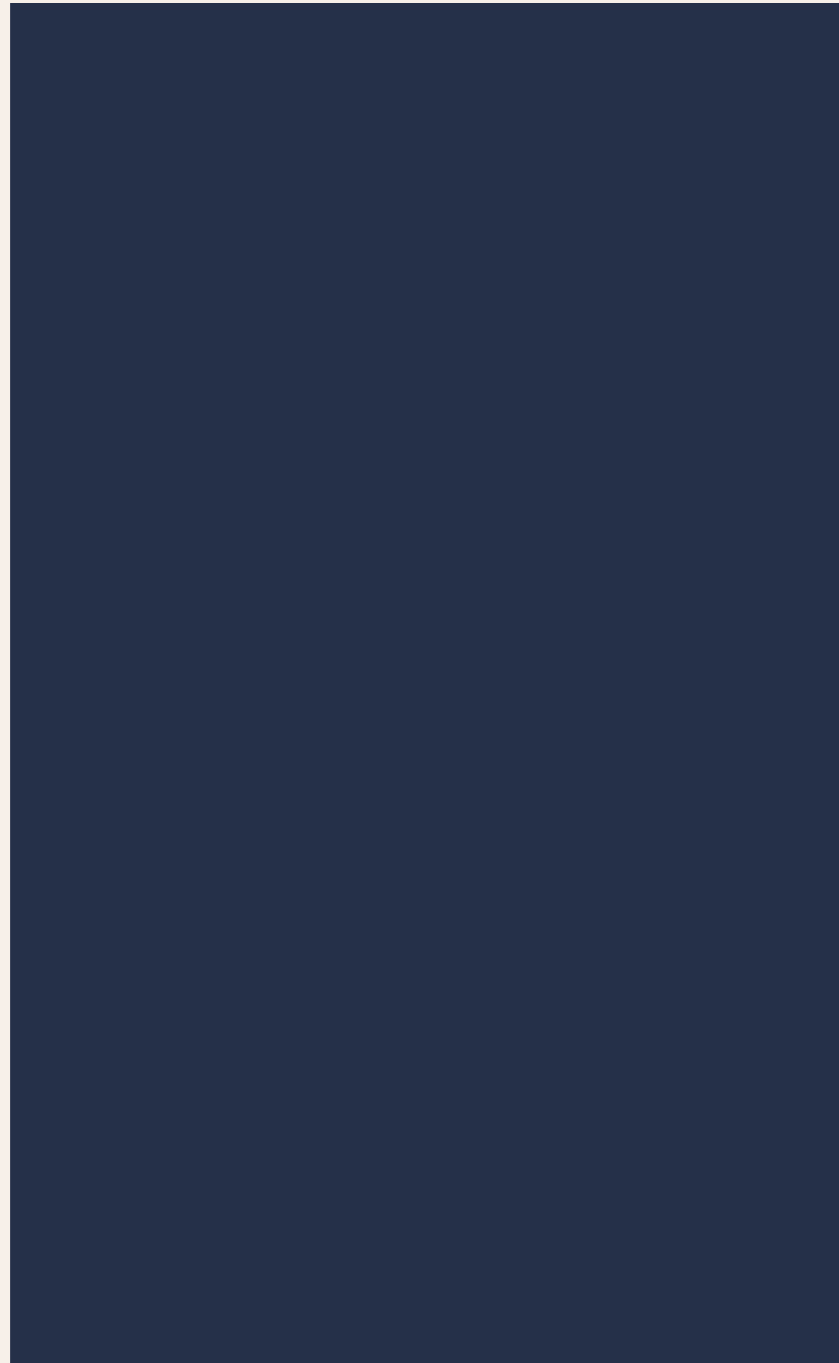

12.

SCHEMI IDRAULICI  
hydraulic plans  
schémas hydrauliques





# SCHEMI IDRAULICI

hydraulic plans . schémas hydrauliques

**CURVE**  
lavaggio  
Art. 9805

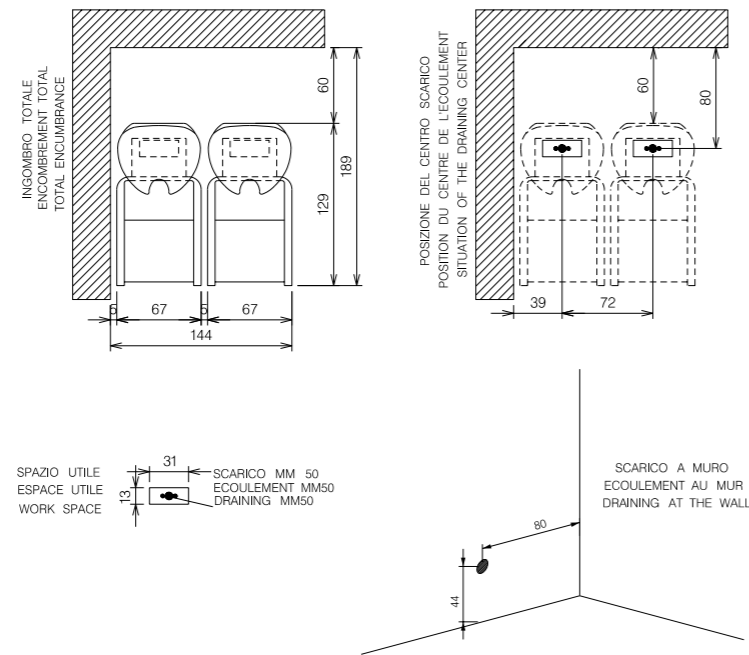

# SCHEMI IDRAULICI

hydraulic plans . schémas hydrauliques

**URBAN**  
relax  
Art. 3855

**URBAN**  
massage  
Art. 3856

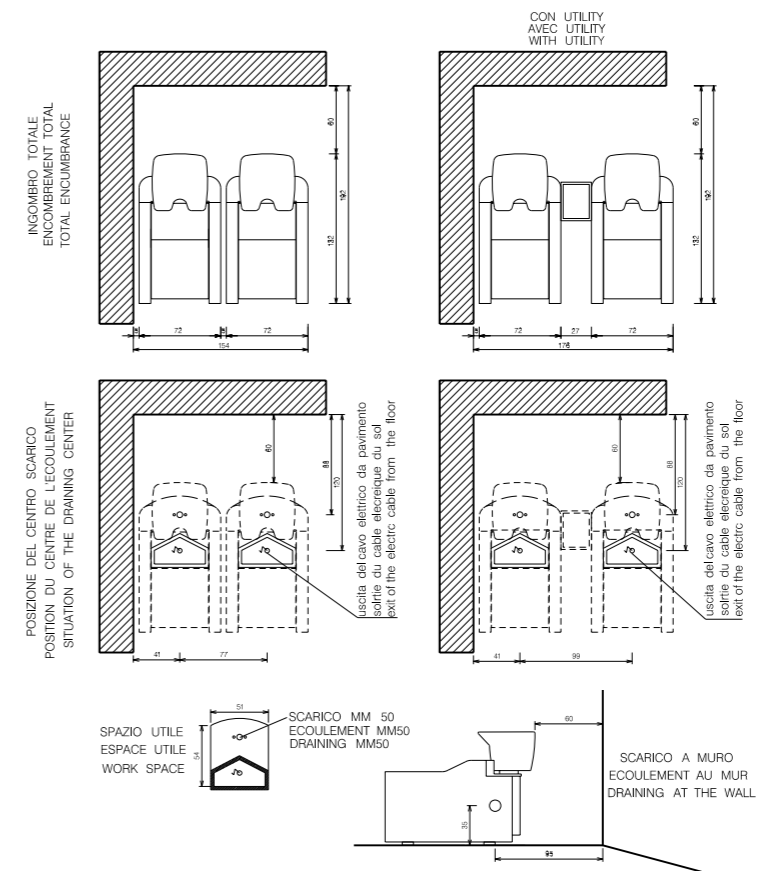

**CURVE**  
relax  
Art. 9806

**CURVE**  
massage  
Art. 9807

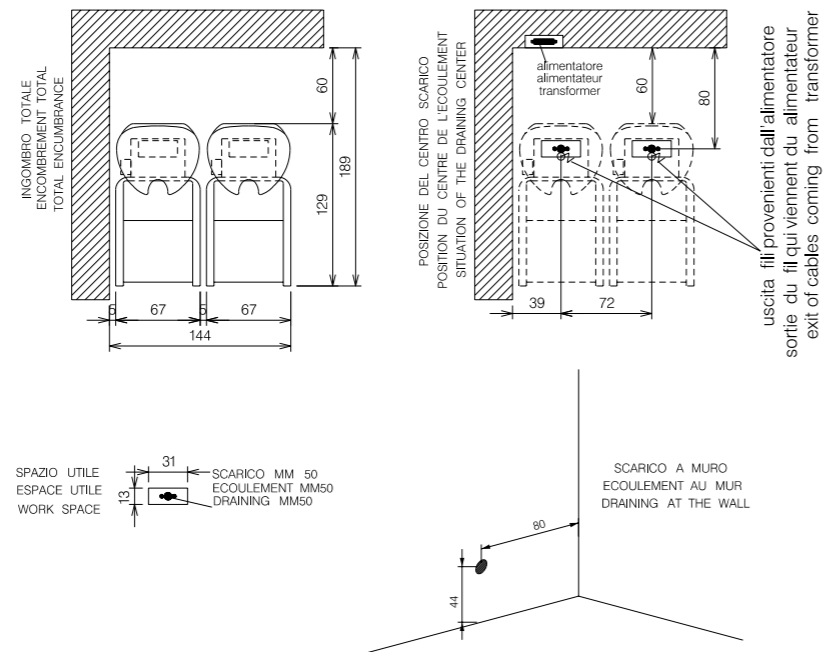

**PUSH-UP**  
relax  
Art. 3350

**PUSH-UP**  
massage  
Art. 3360

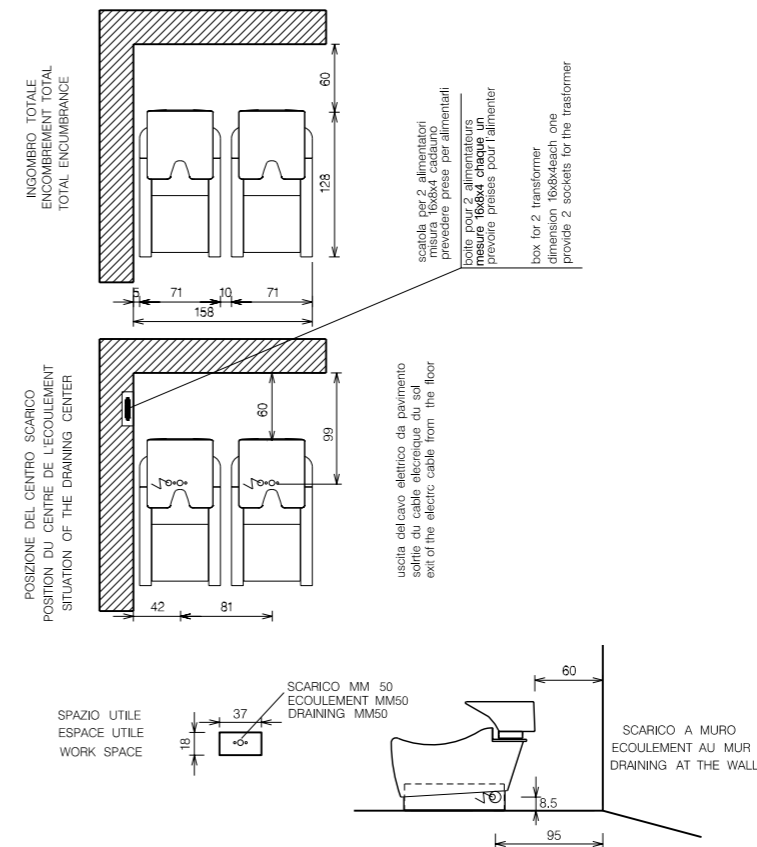

# SCHEMI IDRAULICI

hydraulic plans . schémas hydrauliques

S-RELAX

Art. 9601

S-MASSAGE

Art. 9620

S-COLOR

Art. 9635

S-MAXI

Art. 9640

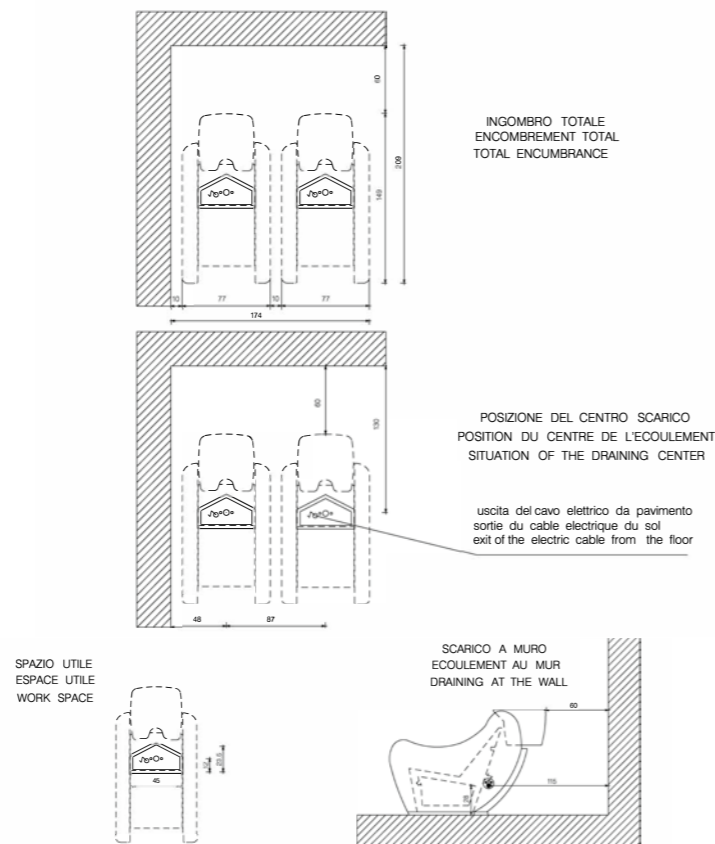

# SCHEMI IDRAULICI

hydraulic plans . schémas hydrauliques

HOP

Art. 3335

HOP

relax

Art. 3340

HOP

massage

Art. 3345

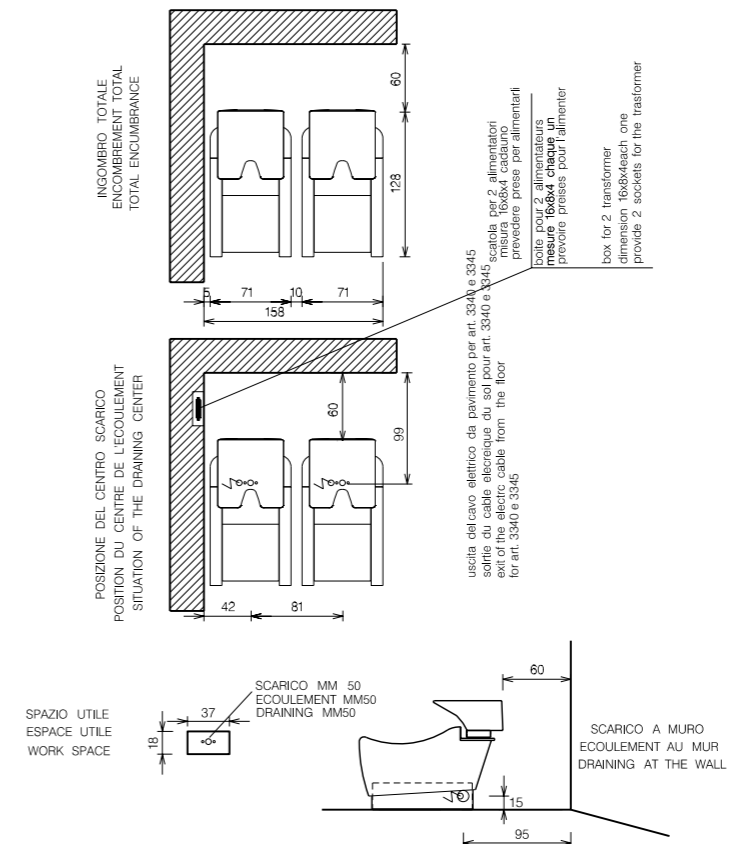

GALAXY  
wash

Art. 3845

GALAXY  
relax

Art. 3850

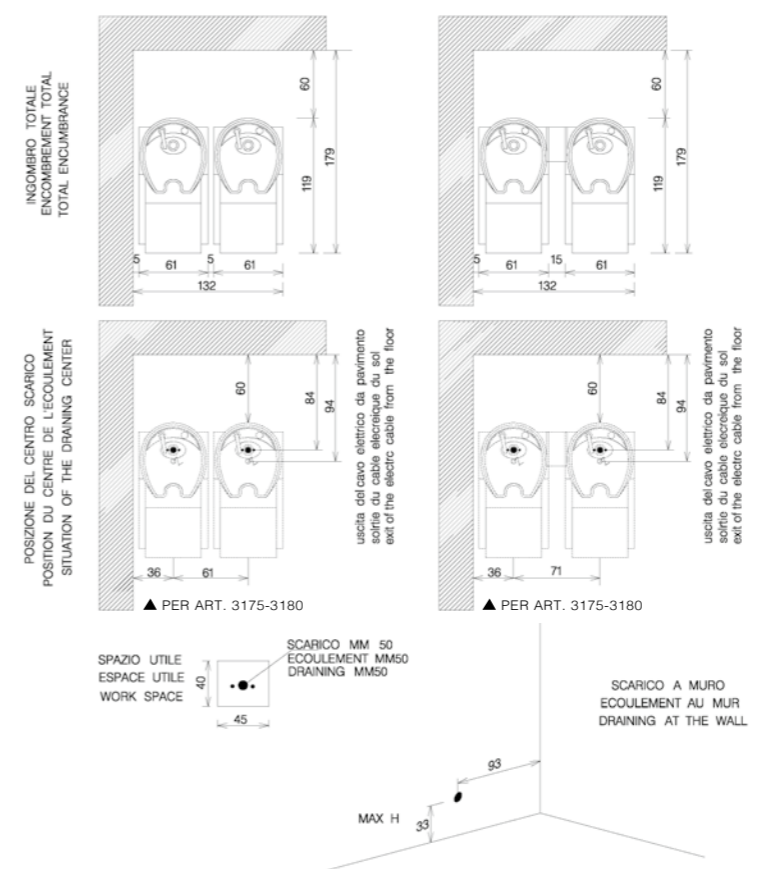
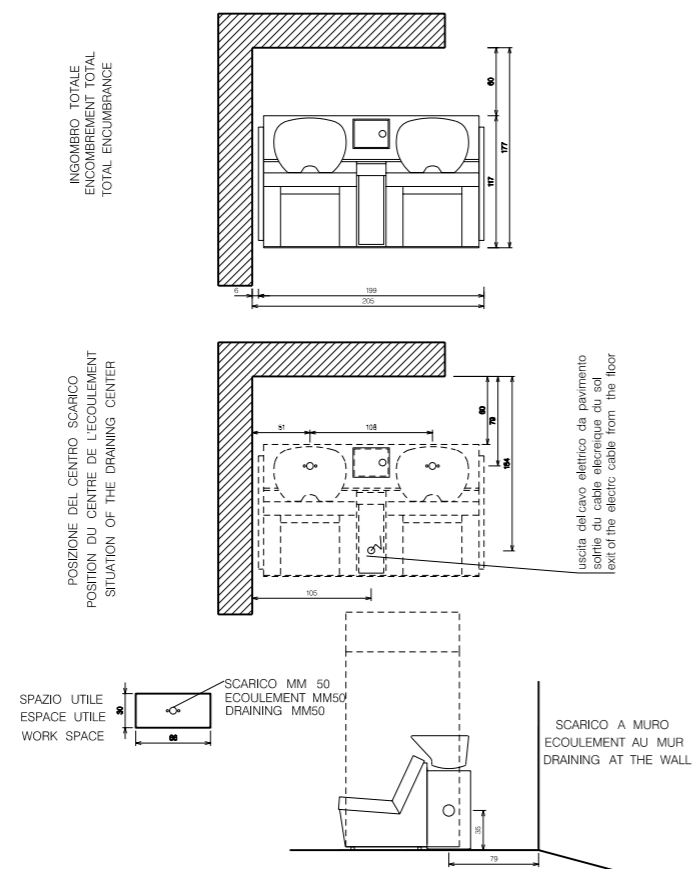

XILEMA  
wash

Art. 3170

XILEMA  
relax

Art. 3180

XILEMA  
massage

Art. 3175

# SCHEMI IDRAULICI

hydraulic plans . schémas hydrauliques

POD  
lavaggio  
Art. 9001

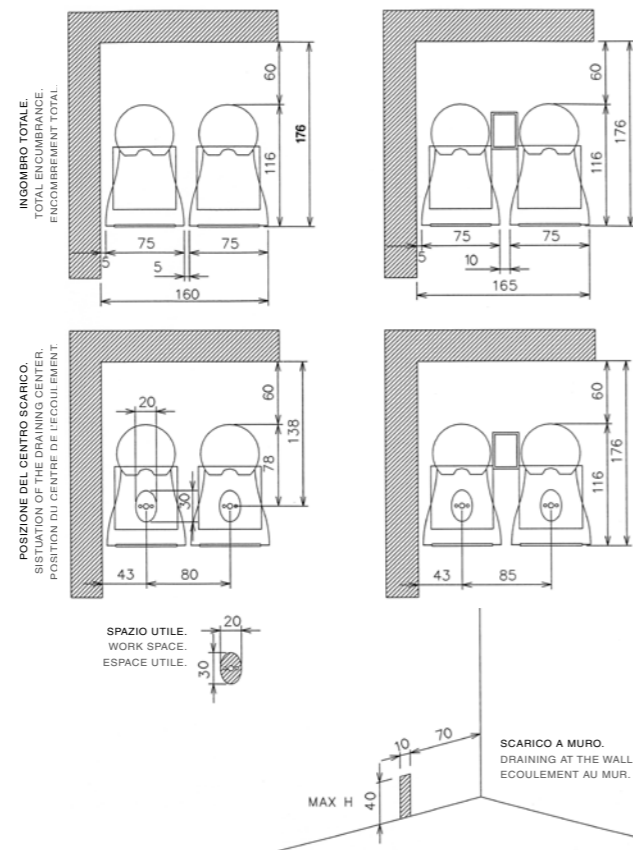

POD  
relax  
Art. 9004

POD  
air massage  
Art. 9003

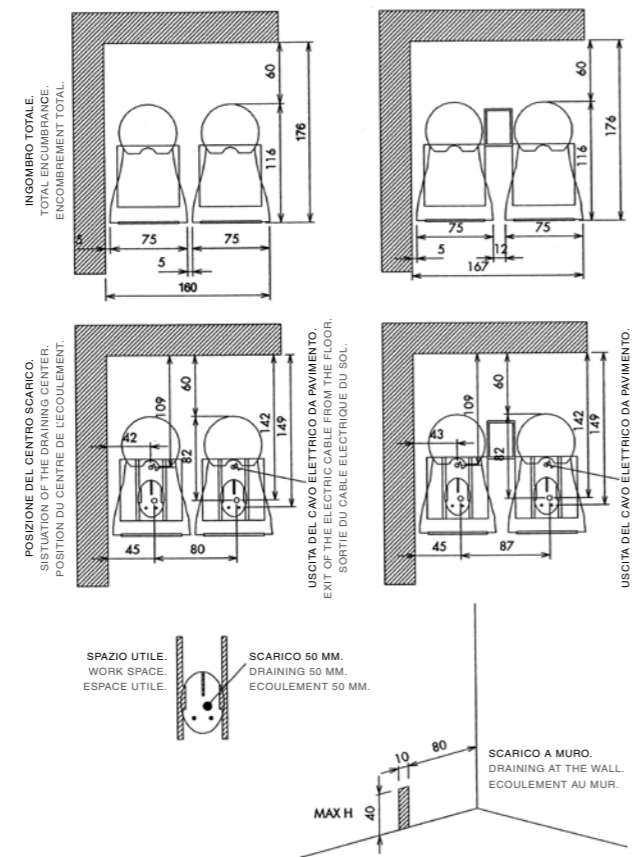

# SCHEMI IDRAULICI

hydraulic plans . schémas hydrauliques

NAPOLEONE  
Art. 3130

NAPOLEONE III  
Art. 3135

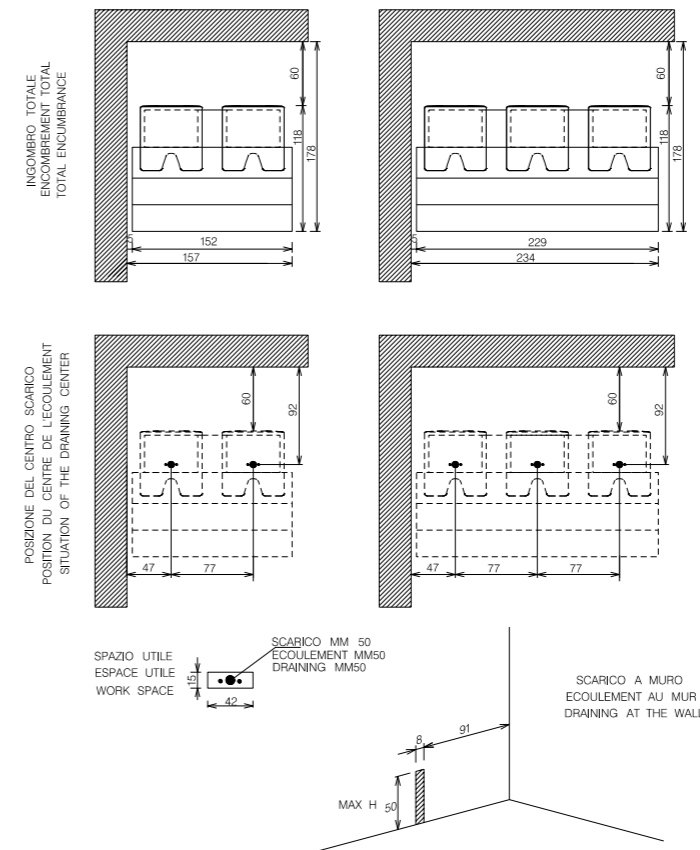

NAPOLEONE  
relax  
Art. 3136

NAPOLEONE III  
relax  
Art. 3137

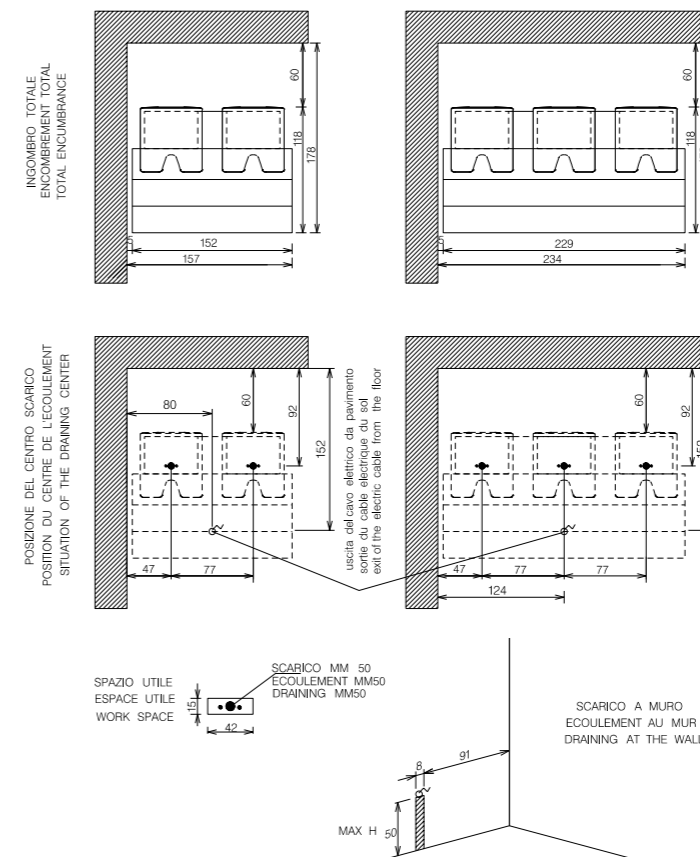



# SCHEMI IDRAULICI

hydraulic plans . schémas hydrauliques

**NEXT**  
Art. 3800

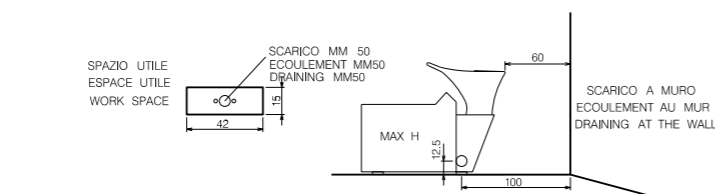
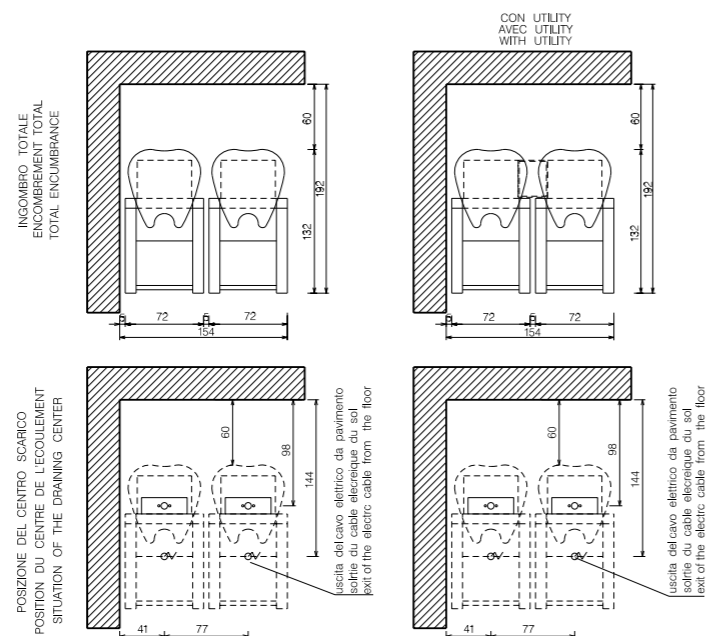
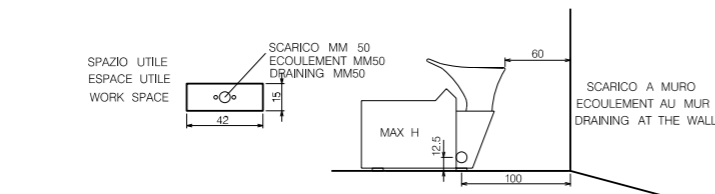
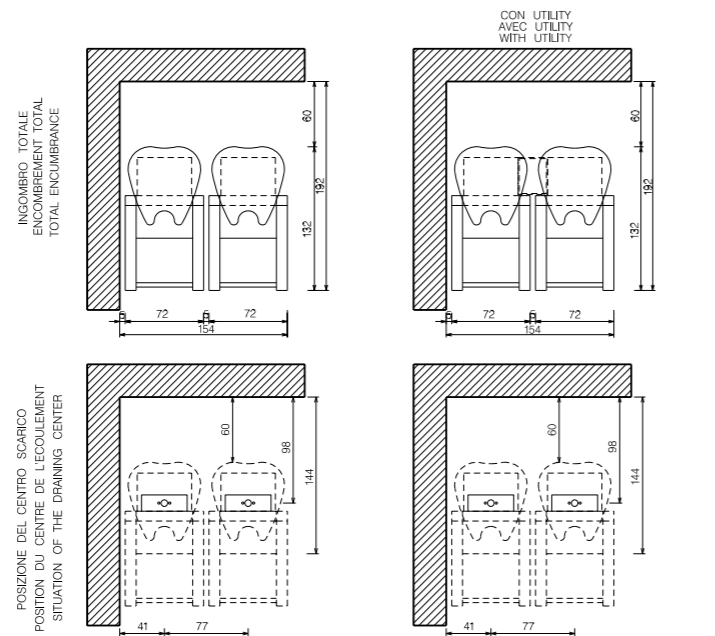

# SCHEMI IDRAULICI

hydraulic plans . schémas hydrauliques

**NIRVANA**  
Art. 3250

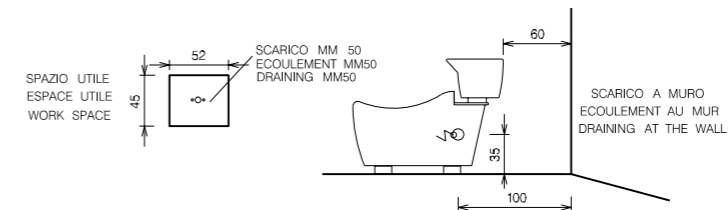
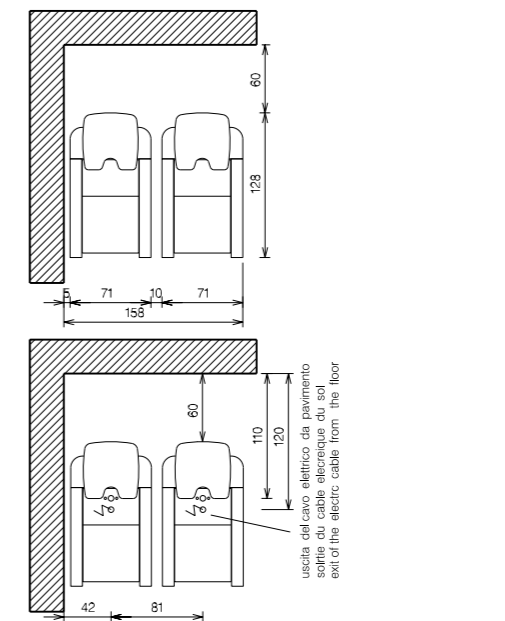
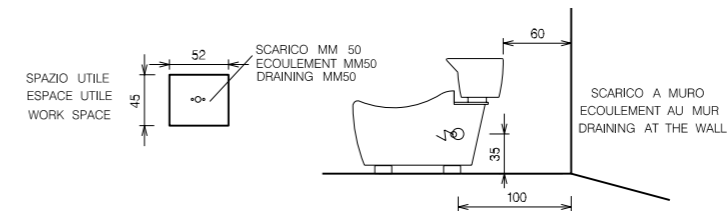
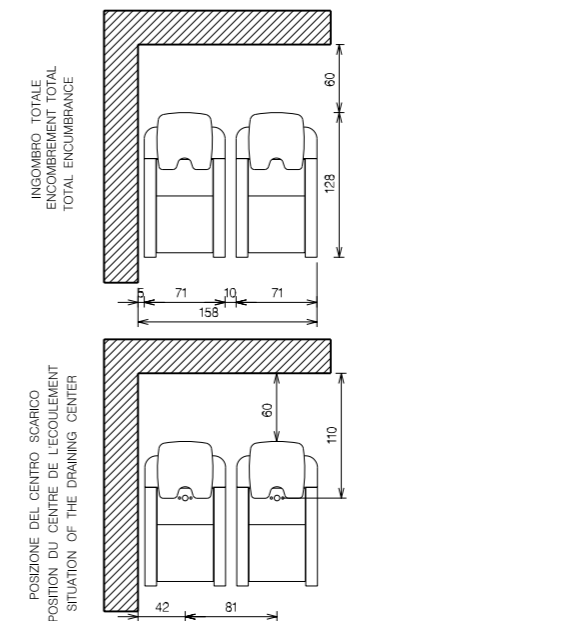

**NEXT**  
relax  
Art. 3802

**NEXT**  
massage  
Art. 3803

**NIRVANA**  
relax  
Art. 3260

**NIRVANA**  
massage  
Art. 3270

# SCHEMI IDRAULICI

hydraulic plans . schémas hydrauliques

# SCHEMI IDRAULICI

hydraulic plans . schémas hydrauliques

JAGO  
Art. 3020

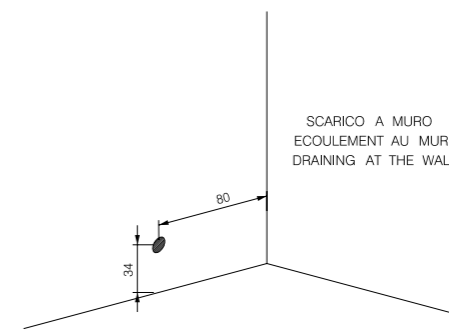
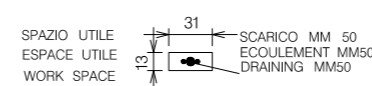
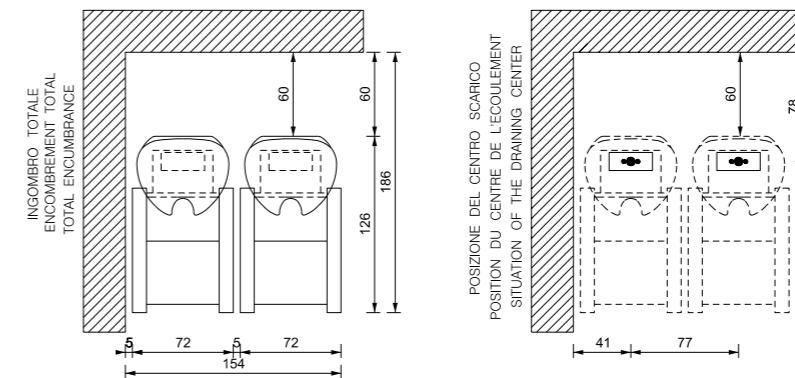
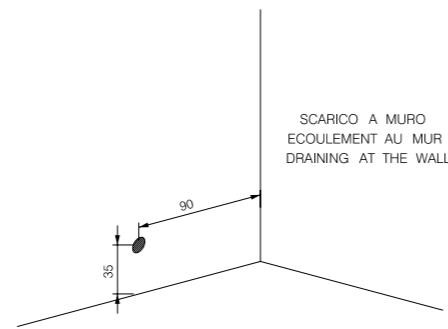
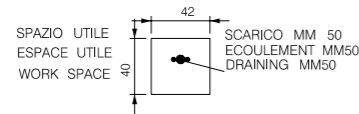
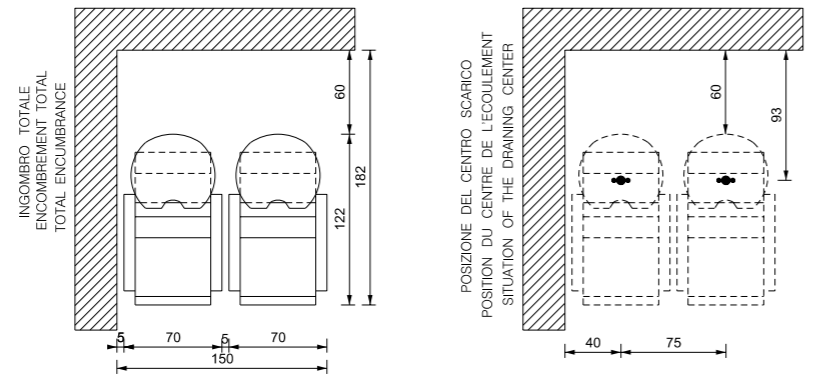

JAGO  
relax  
Art. 3025

JAGO  
massage  
Art. 3030

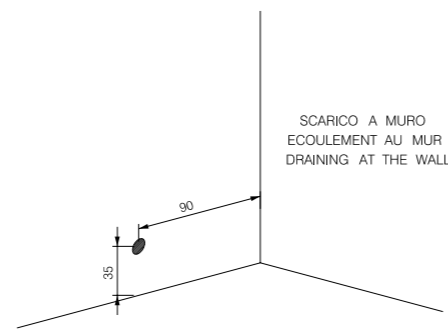
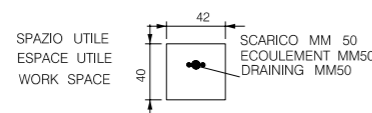
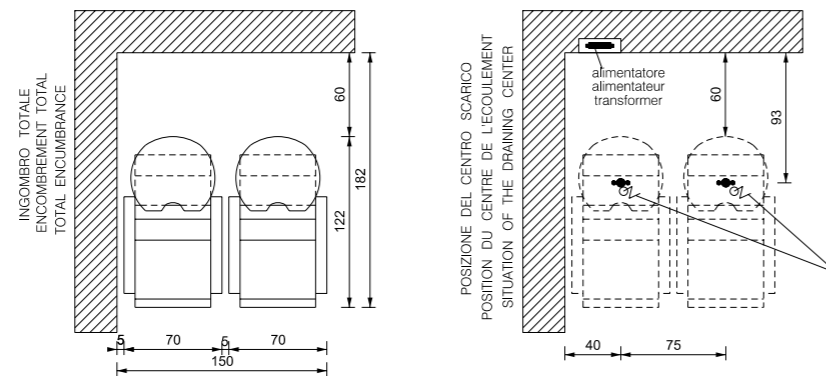

uscita fili provenienti dall'alimentatore  
sortie du fil qui viennent du alimentateur  
exit of cables coming from transformer

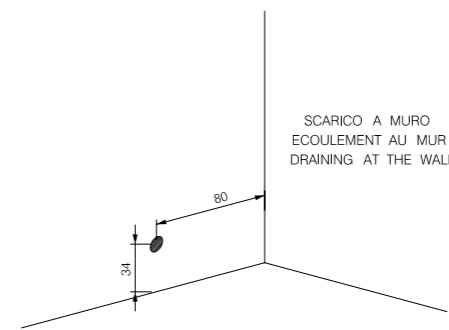
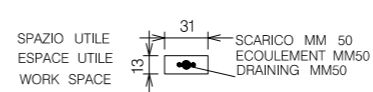
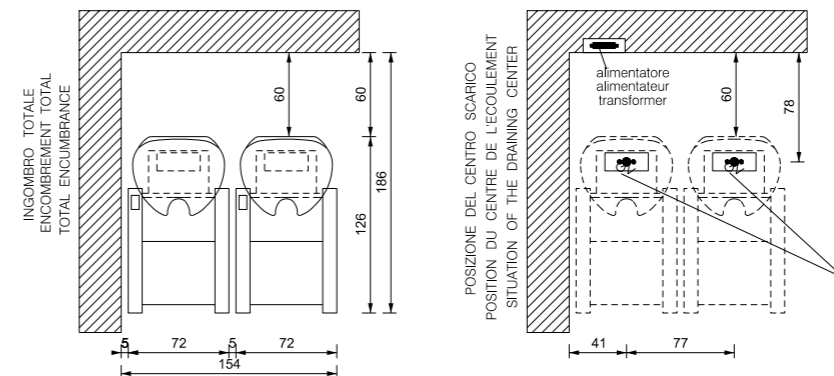

uscita fili provenienti dall'alimentatore  
sortie du fil qui viennent du alimentateur  
exit of cables coming from transformer

COOPER  
Art. 3080

COOPER  
relax  
Art. 3085

COOPER  
massage  
Art. 3090

# SCHEMI IDRAULICI

hydraulic plans . schémas hydrauliques

**DYLAN**  
Art. 3295

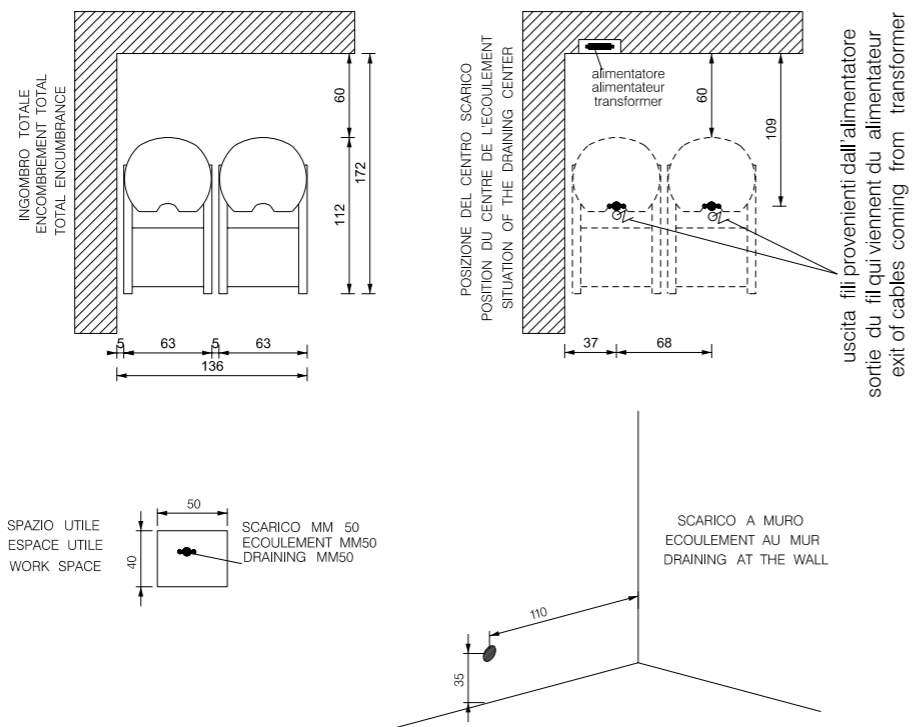
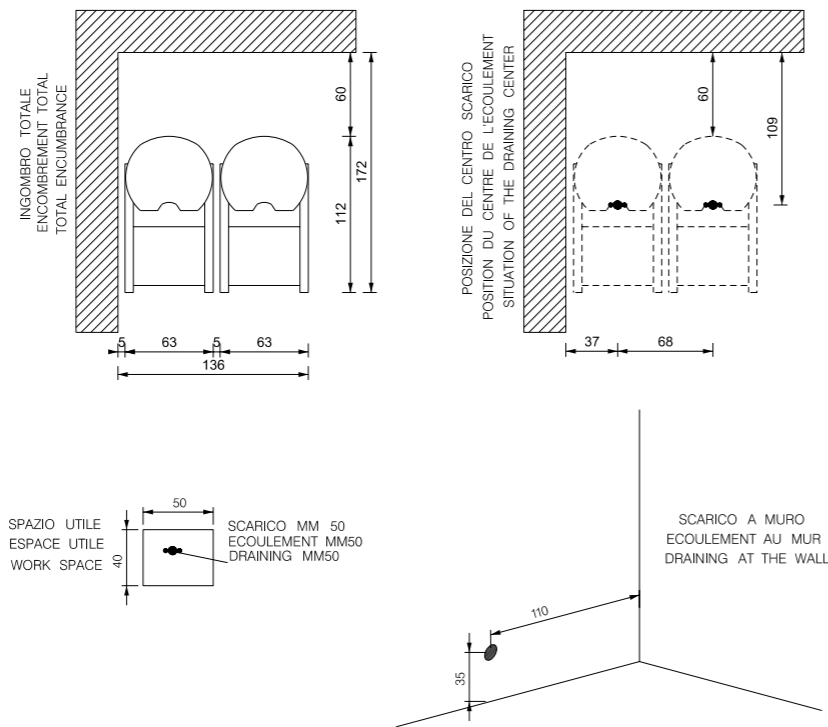

**DYLAN**  
relax  
Art. 3300

**DYLAN**  
massage  
Art. 3305

# SCHEMI IDRAULICI

hydraulic plans . schémas hydrauliques

**KUBIK**  
flat  
Art. 3197

**KUBIK**  
flat relax  
Art. 3199

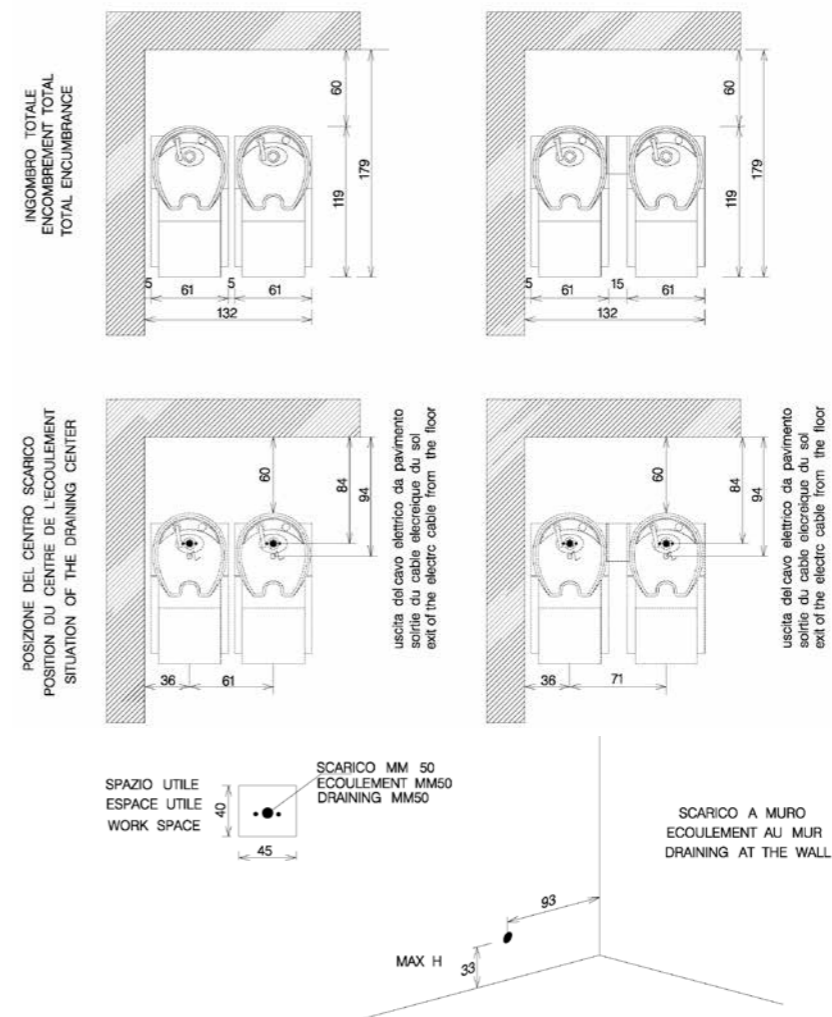



# SCHEMI IDRAULICI

hydraulic plans . schémas hydrauliques

**EDDIE**  
Art. 8060/16

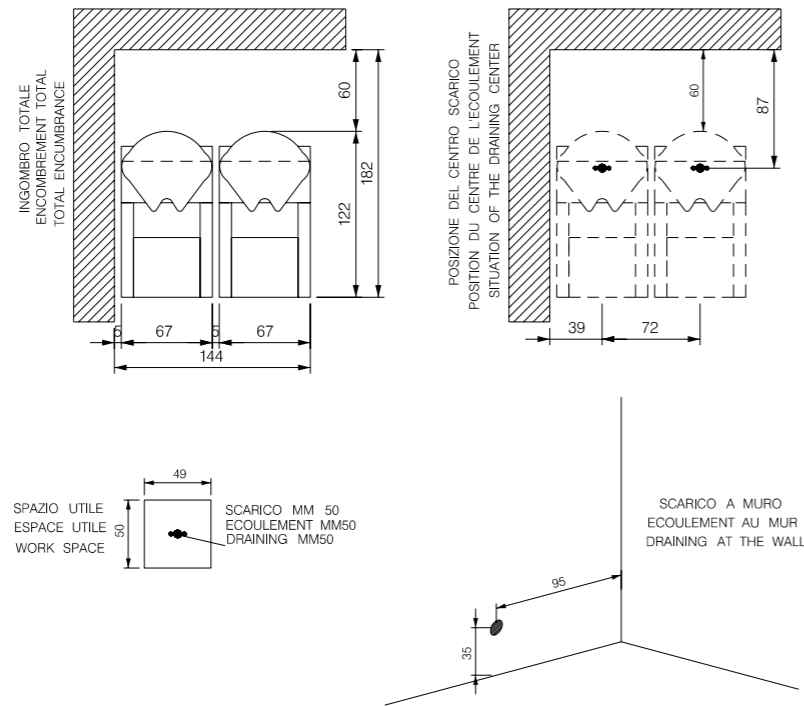

# SCHEMI IDRAULICI

hydraulic plans . schémas hydrauliques

**EDDIE SOFÁ**  
Art. 8066

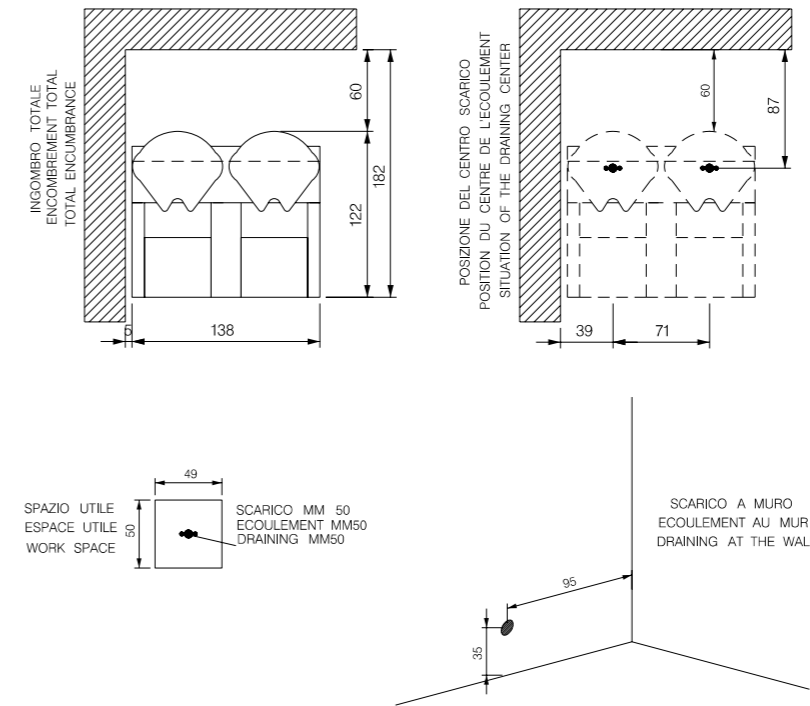

**EDDIE**  
relax  
Art. 8065/16

**EDDIE**  
massage  
Art. 8069/16

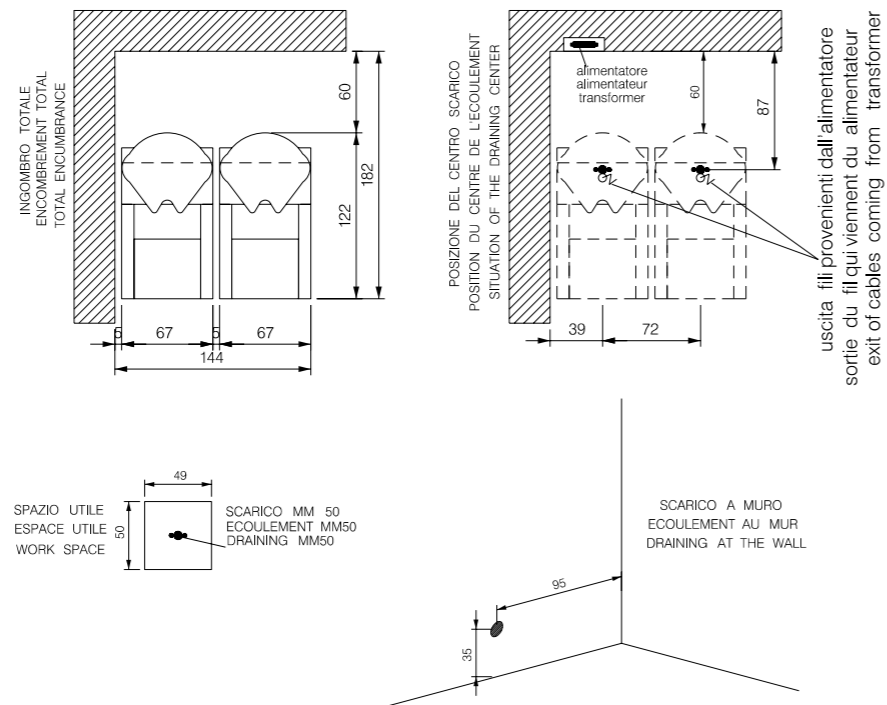

**EDDIE SOFÁ**  
relax  
Art. 8067

**EDDIE SOFÁ**  
massage  
Art. 8068

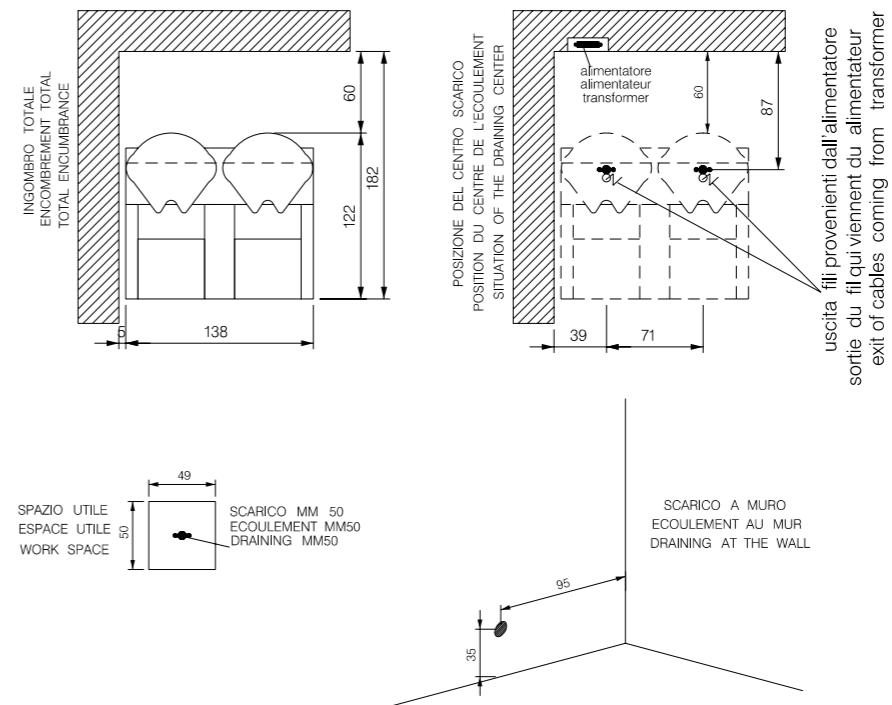

# SCHEMI IDRAULICI

hydraulic plans . schémas hydrauliques

ROYAL WASH  
Art. 8070

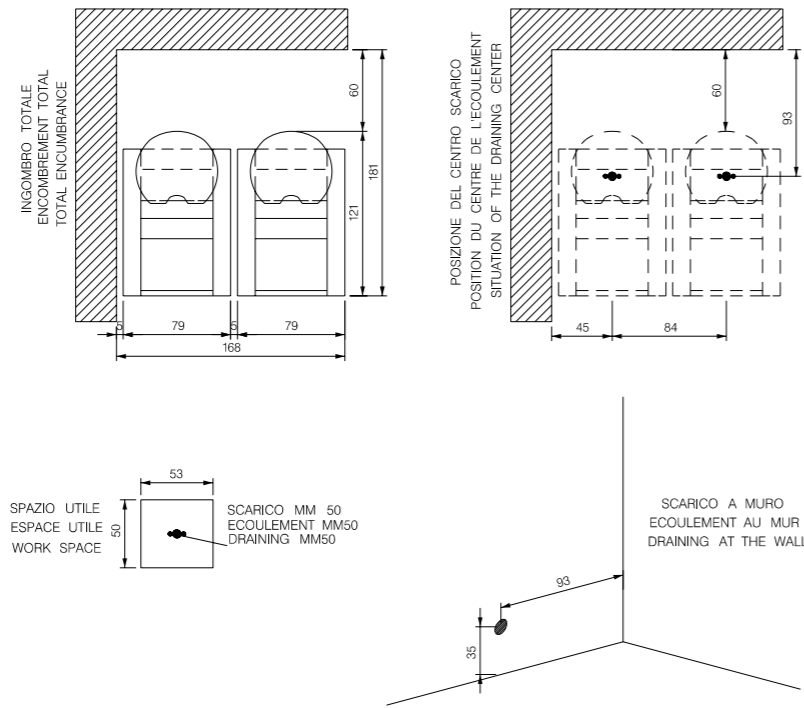

ROYAL WASH  
relax  
Art. 8075

ROYAL WASH  
massage  
Art. 8077

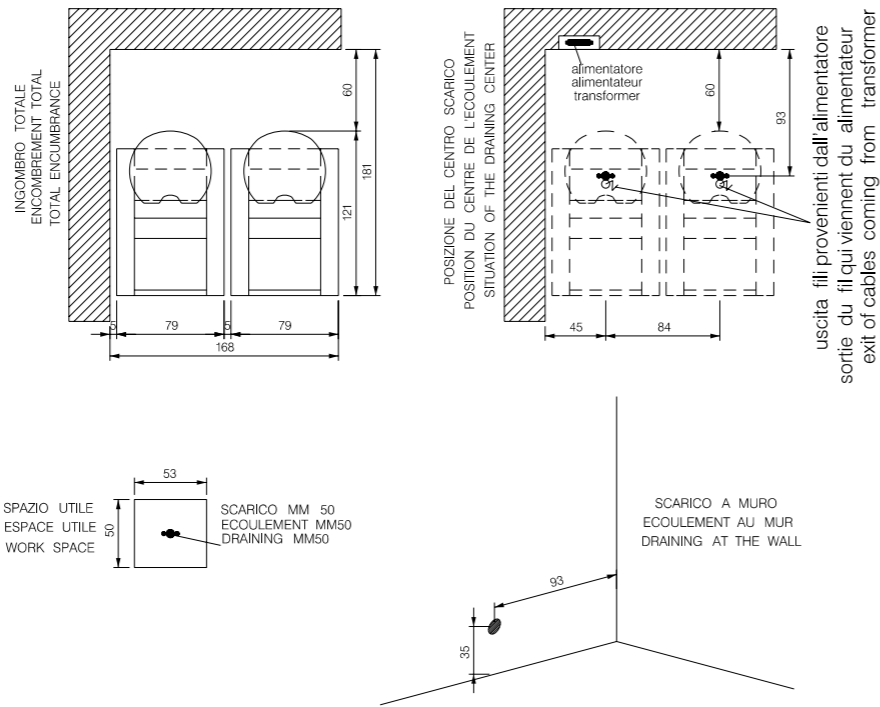

# SCHEMI IDRAULICI

hydraulic plans . schémas hydrauliques

JO-WASH  
Art. 8080

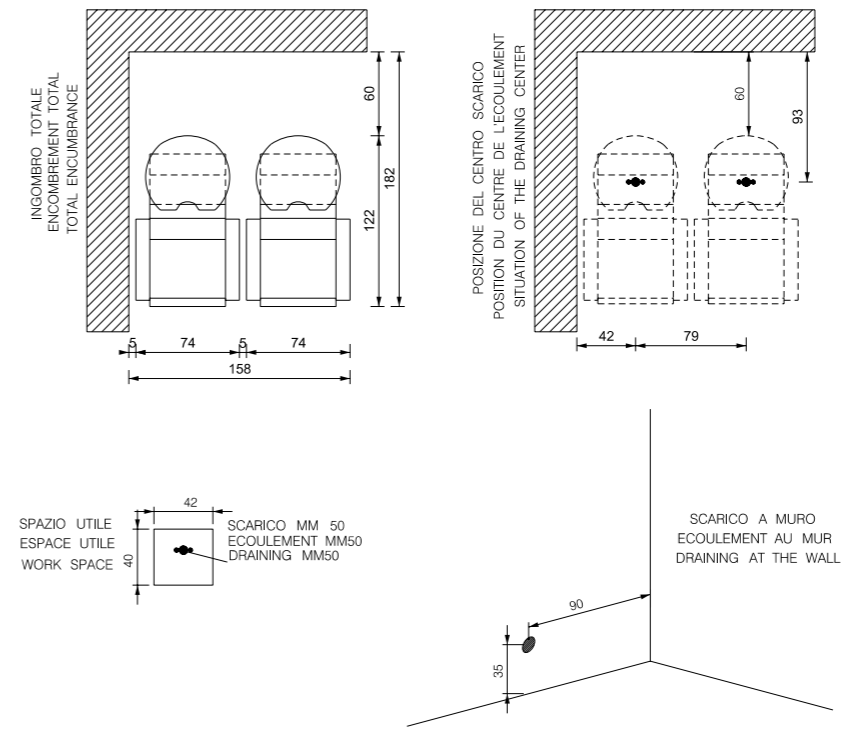

JO-WASH  
relax  
Art. 8085

JO-WASH  
massage  
Art. 8087

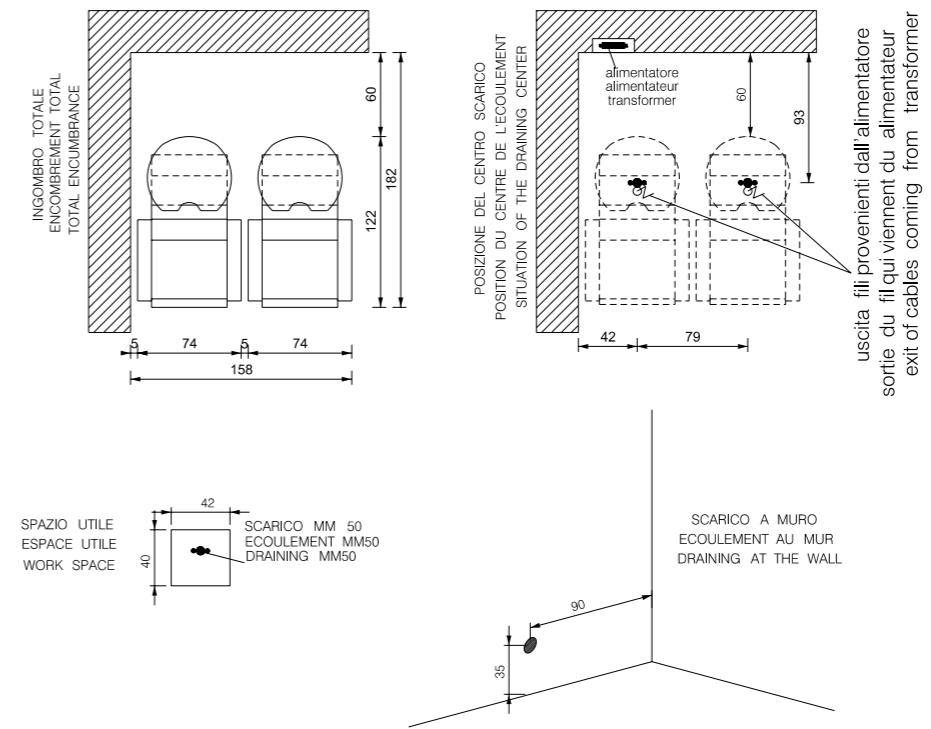



# 13.

COLORI E MATERIALI  
colours and materials  
coloris et matériaux





NORMAL  
SKAI

TAPPEZZERIA  
upholstery . tapiserie



TAPPEZZERIA  
upholstery . tapiserie

SPECIAL  
SKAI

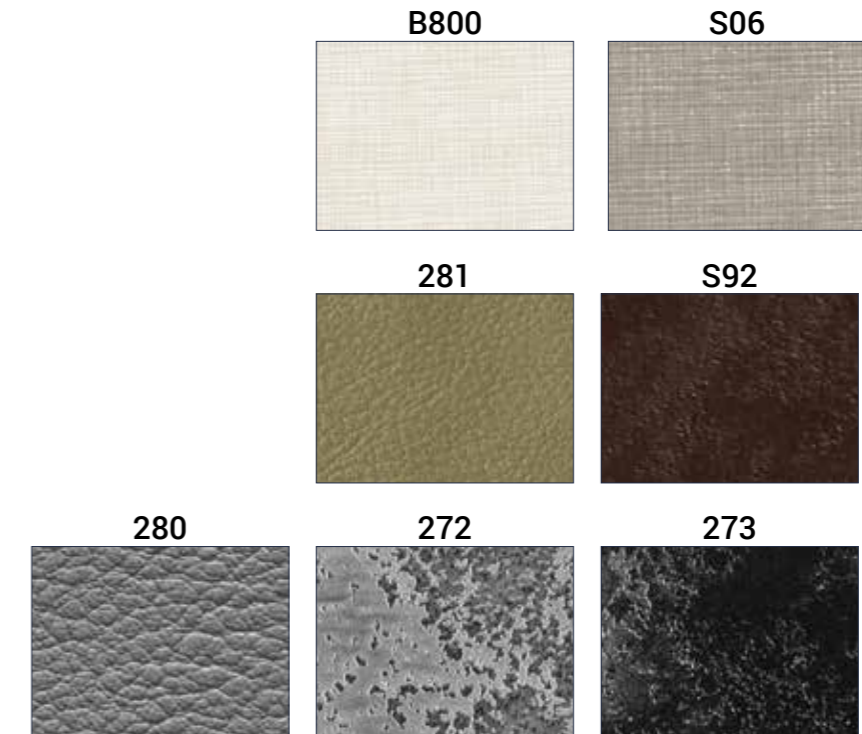

TAPPEZZERIA  
upholstery . tapisserie



LAMINATI  
plastic laminated . stratifiés



NOBILITAT O . pre-laminated . laminé



Le informazioni contenute nel presente catalogo sono il più possibile esatte, ma non sono da ritenersi vincolanti. Il colori e gli effetti riportati sul presente catalogo sono indicativi per i limiti consentiti dalla stampa; per questo non possono essere vincolanti e costituire base per eventuali contestazioni.

*The information contained in this catalogue is as accurate as possible, but cannot be considered as legally binding. Colours and aesthetic effects shown on this catalogue should be considered indicative and approximate as a result of printing process limits. Possible variations may occur and can not be at the base of any claim.*

*Les informations reprises dans ce catalogue sont exactes, mais elles n'engagent aucunement notre Société du point de vue légal. Les couleurs et les effets présentés dans ce catalogue sont indicatifs dans la mesure permise par la presse, ce qui explique pourquoi ils ne peuvent pas être obligatoire et constituer la base d'un éventuel désaccord.*

VEZZOSI srl  
Via Martiri della Romania, 9  
42020 Borzano  
Albinea (RE) - Italy  
Tel. +39 0522 591721  
Fax +39 0522 591298

[www.vezzosiarredamenti.com](http://www.vezzosiarredamenti.com)  
[info@vezzosiarredamenti.com](mailto:info@vezzosiarredamenti.com)

Coordinamento: MKTG.  **VEZZOSI**

Credit: EUREKA

Stampa: ????????????

Marzo 2019



[vezzosiarredamenti.com](http://vezzosiarredamenti.com)

